

AEROCOMPACT®

ENGLISH

FLEXIBLE IN
APPLICATION
AND MAXIMUM
SAFETY

COMPACTFLAT S15

WITH THE COMPACTFLAT S SYSTEM, WE REVOLUTIONIZED THE WORLD OF PV SUBSTRUCTURES. WE CHALLENGED THE STANDARD RAIL SUBSTRUCTURES ON THE MARKET AND DESIGNED SUBSTRUCTURES BASED ON ALUMINUM BRACKETS, MAKING A NAME FOR OURSELVES WORLDWIDE.

INTELLIGENT SOLAR RACKING

- + Short assembly times
- + Low transport costs
- + Few components
- + Maximum safety due to extensive wind tunnel tests
- + Incl. pre-assembled PES protection pad
- + Module clamps with integrated grounding pins

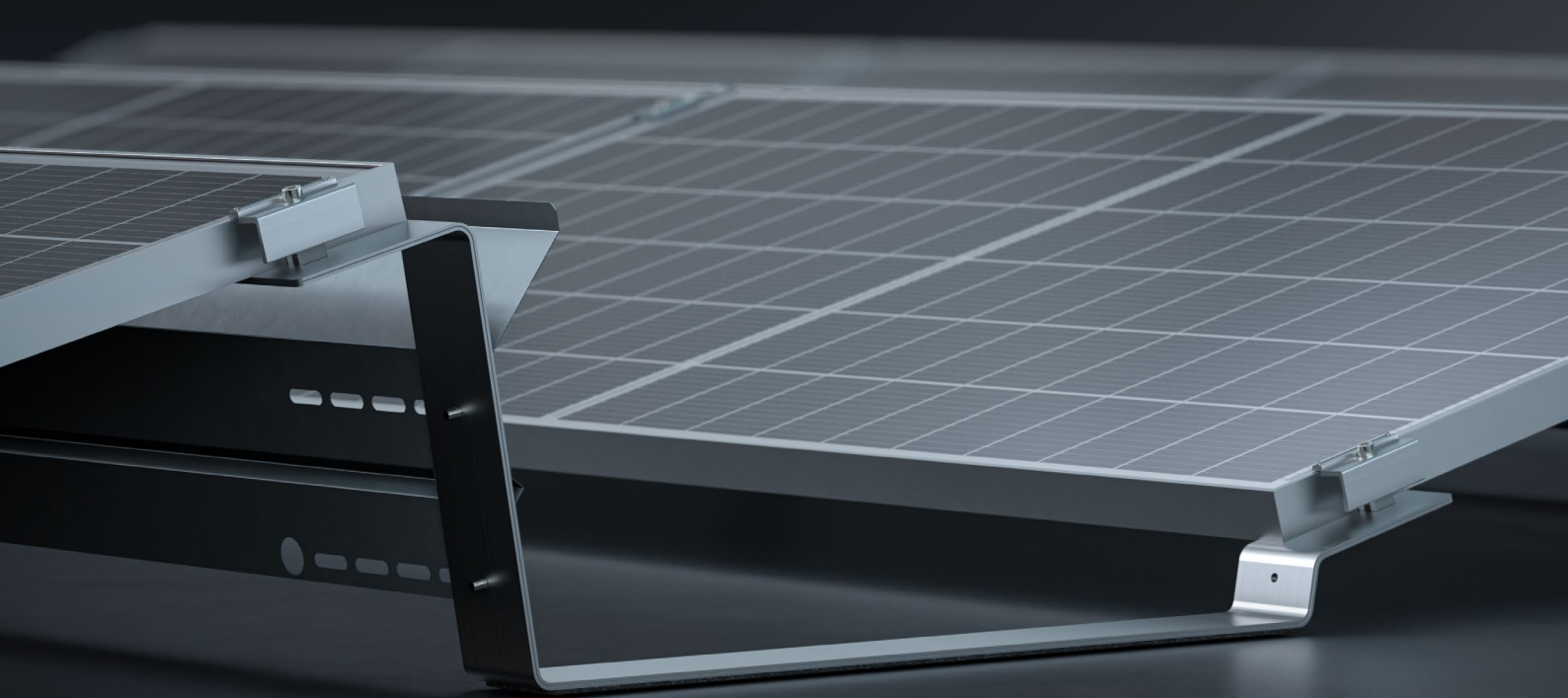

BRACKET SYSTEM – SOUTH 15°

COMPACTFLAT S15

The COMPACTFLAT S15 is another south-facing aerodynamic flat roof fastening system including pre-assembled PES building protection mat for framed PV modules. It is available with an inclination of 10° and 15°, as well as various row spacings and is available as an alpine version as well.

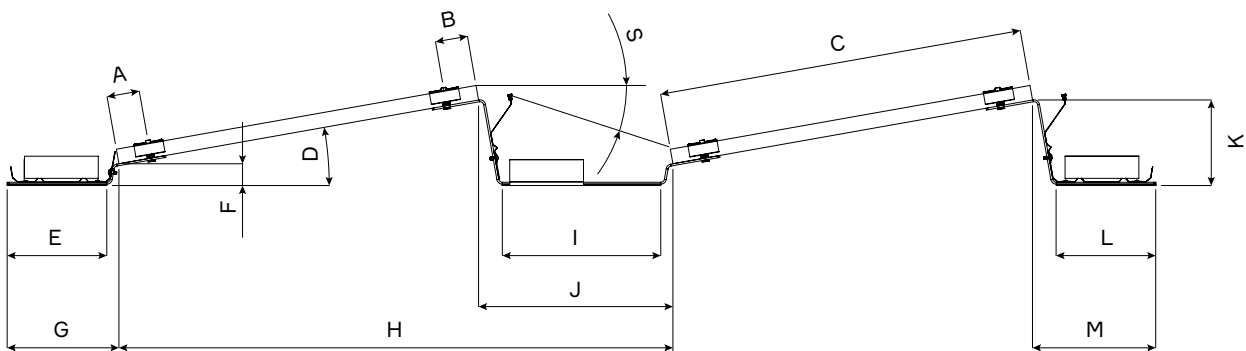

| | A [mm] | B [mm] | C* [mm] | D [°] | E [mm] | F [mm] | G [mm] | H* [mm] | I [mm] | J [mm] | K [mm] | L [mm] | M [mm] | S [°] |
|------------------------------|-----------|-----------|------------|----------|-----------|-----------|-----------|------------|-----------|-----------|-----------|-----------|-----------|----------|
| S15 – 571 mm – Short spacing | 88,5 | 88,5 | 950–1150 | 15 | 270 | 60 | 303 | 1486–1692 | 458 | 571 | 317 | 270 | 350 | 25 |
| S15 – 790 mm – Long spacing | 88,5 | 88,5 | 950–1150 | 15 | 270 | 60 | 303 | 1705–1911 | 677 | 790 | 317 | 270 | 350 | 18 |

* depending on the PV-module dimensions

ADDITIONAL COMPONENTS

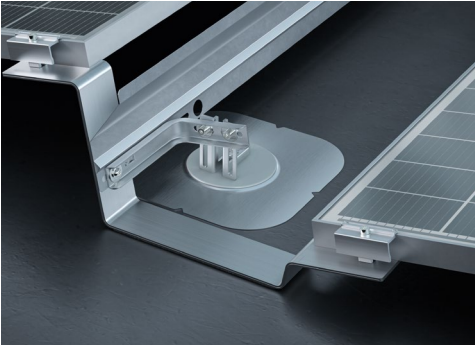

ROOF CONNECTION

AEROCOMPACT offers a sophisticated hybrid solution for roofs that cannot withstand the additional weight of a photovoltaic system. The combination of roof fastening points and ballast reduces the overall weight of the system. This option can also be used in areas with seismic activity to prevent the system from shifting due to earthquake influences.



ALPINE VERSION

Our alpine version is used from a certain snow load, which is calculated by our online software AEROTOOL based on the project.

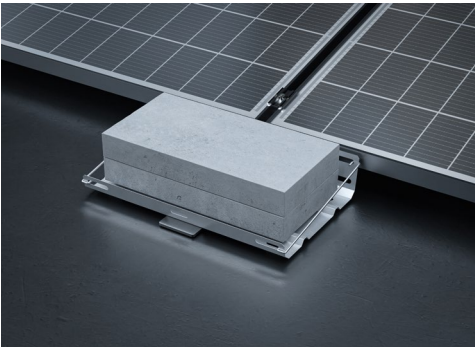

BALLAST TRAYS

This system variant with ballast trays, available in various sizes, is mainly used in areas with high wind loads and roofs with low point loads. The main advantages of this installation variant are, on the one hand, the additional ballast that can be installed per module and, on the other hand, the even distribution of the concentrated load on the roofing. The ballast tray can also be used for ballasting on gravel roofs by putting the gravel into the ballast trays. With the additional ballast securing bracket, the ballast stones are secured against slipping from the tray and ideally distributed.



CABLE MANAGEMENT

The cable management solution for string cabling of the rows is UL-certified and available as a standard product.

AEROCOMPACT®

- + No roof penetration
- + suitable for roof edge areas
- + Wind tunnel-tested
- + Pre-installed building protection mat
- + Quickest installation: 1 kWp / 5 min. / 2 people
- + Developed in Austria

| | |
|------------------------------------|---|
| DESCRIPTION | Aerodynamic installation system for the stand-mounting of framed PV modules on flat roofs. |
| AREA OF APPLICATION | On foil and bitumen roofs with and without heat insulation beneath the sealing, as well as on concrete roofs; can be adapted for gravel and green roofs upon request |
| MODULE DIMENSIONS | 950 – 1.150 mm × 1.500 – 2.250 mm (width × length) |
| INSTALLATION ANGLE | 15°, unilateral |
| DISTANCE TO ROOF SURFACE | Approx. 60 mm; potentially less on gravel roof |
| DISTANCE FROM THE ROOF EDGE | 1.200 mm (less corner spacing upon request) |
| MAX. ROOF INCLINATION | Up to 5° possible without roof anchors; above 5° only with roof anchors |
| MAX. FIELD SIZE | 12 × 10 rows; 120 modules |
| MIN. FIELD SIZE | 1 rows for every 2 modules |
| WIND LOAD | Up to 2.4 kN/m ² |
| SNOW LOAD | S15 standard: up to 2.4 kN/m ² , S15 alpine: up to 4.4 kN/m ² |
| DESIGN / PROOF OF STABILITY | Software-supported based on wind tunnel analyses |
| ON-SITE REQUIREMENTS | Sufficient structural load-bearing capacity of the roof structure and the building's supporting structure, as well as adequate compressive strength of the roof structure, must be ensured on site. The general terms and conditions, terms of warranty, and the user agreement apply. |
| COMPONENTS | Module clamps with grounding pins, flat-roof brackets, wind deflector plates, ballast stones; optional lateral plates, ballast trays, roof anchors |
| MATERIALS | Bearing connecting parts made from aluminum EN AW 6060 T64; module clamps made from aluminum EN AW 6063 T66; screws made from stainless steel A2-70; wind deflector plates and ballast trays made from steel with aluminum-zinc coating; building protection mat made from polyester fleece |