

Assembly Instruction

COMPACTFLAT SN 2 PLUS longside

Version : 3.3

Language : English

Important! Read carefully before installation!

Legal Notice

Subject to change due to technical modifications! These assembly instructions correspond to the technical status of the delivered product and not to the current development status at the manufacturer. If pages or parts of the assembly instructions are missing, please contact the manufacturer's address given below. The original language of these assembly instructions is German. Any assembly instructions in another language are a translation of the assembly instructions in German. Therefore, in case of doubt or contradiction, the authentic German version shall prevail. The installation instructions are protected by copyright. The installation instructions may not be copied, reproduced, microfilmed, translated or converted for storage and processing in computer systems, either in part or in full, without the written permission of AEROCOMPACT Europe GmbH

Copyright by AEROCOMPACT Europe GmbH

Manufacturer

AEROCOMPACT Europe GmbH
Gewerbestrasse 14
6822 Satteins, Austria

office@aerocompact.com
www.aerocompact.com

Creation date

01/2025

TOC

General	4
Applicable documents	4
Limitation of liability	4
Explanation of symbols	4
Safety	5
Appropriate use	5
Personnel requirements	6
Working safely	6
Personal protective equipment (PPE)	6
Structure of the warnings according to hazard levels	7
System overview	8
SN2 PLUS 10°	8
SN2 PLUS 5°	10
System accessories	12
Assembly	13
Assembly preparation	13
Required tools for assembly	13
Information on mounting on gravel roofs	13
Install the system on waterproofing or protective fleece	13
Set up the system on the gravel	13
Wide base rails	14
Measure the module field	15
Base rail connector	16
Attach additional structural protection pads (optional)	17
Attach construction protection mats to cut-to-size base rails	18
Protection pads for level compensation	18
SN2 Mounting gauge	19
Positioning the base rails	19
Position brackets	20
Mount brackets	22
Mount front bracket	22
Mount rear bracket 5°	22
Mount rear bracket 10°	23
Variants	24
Mount modules	26
Ballasting	28
Ballast clamp	28
Positioning the ballast	29
Cross struts	30
Possible mounting positions of the cross struts	30
Mounting the cross-member with preassembled option	30
Connect module rows	31
Secure ballast with cross-members	32
Mount the double roof anchor connection (optional)	33
Install single roof anchor connection (optional)	34
SN2 Cable management	35
Potential equalization	39
Maintenance, disassembly and disposal	41
Maintenance	41
Disassembly	41
Disposal	41
Appendix	42
Declaration of performance	42
Revision history	42

GENERAL

These assembly instructions describe the assembly procedure and must be strictly adhered to. Read these installation instructions carefully before starting installation. The basic prerequisite for safe working is compliance with all the safety and handling instructions in these installation instructions. In addition, the local accident prevention regulations and general safety regulations for the area of application of the product apply. Illustrations in these instructions are for basic understanding and may differ from the actual design.

APPLICABLE DOCUMENTS

In addition to this manual, you have received an AEROTOOL project report, planning documents and drawings. Always comply with the instructions and notes contained therein.

LIMITATION OF LIABILITY

All information and instructions in these assembly instructions have been compiled taking into account the applicable standards and regulations, the state of the art and our many years of knowledge and experience. Liability provisions are stated in our **terms** and can be accessed at www.aerocompact.com/downloads.

EXPLANATION OF SYMBOLS

SYMBOLS FOR INSTRUCTIONS



Prerequisites for action instruction



Results of action steps



Step by step action instruction



This note provides useful information for smooth installation

SYMBOLS IN ILLUSTRATIONS - ACTIVITIES



Optional component, optional mounting variation



Activity by hand



Check AEROTOOL project report or planning documents



Visual inspection



Observe right angle



Assembly tip

SYMBOLS IN ILLUSTRATIONS - TOOLS



Measuring tape, measure



Pencil, mark



Chalk line



Scissors, tin snips, cut to size



Cordless screwdriver, screwdriver



Use a torque wrench, Observe torque



Use Allen key

SAFETY

The following list serves as an indication of the most common safety risks that can occur when installing these products. There is no liability for the completeness of the risks presented. A specific check of the necessary safety measures must be carried out by an authorized specialist company before installation.

APPROPRIATE USE

The CompactFLAT flat roof system is designed exclusively for mounting PV modules on flat roofs or similar flat surfaces. Proper use also includes correct installation in accordance with these installation instructions. Installation must be carried out by qualified personnel who are familiar with the installation of photovoltaic systems and strictly in accordance with the installation instructions, planning documents and project report. The building protection mat included in the scope of delivery is matched to the roof surface defined in the project. Due to the large number of different types of waterproofing used in the past and currently available on the market, the responsible planner must ensure compatibility and the static friction coefficient between the building protection mat and the roof structure of the building on which the system design is based. The friction coefficient is determined during the planning process using the Friction Measurement Kit.

PERSONNEL REQUIREMENTS

Installation may only be carried out by a specialist company and must be carried out strictly in accordance with the installation instructions, the project report and the planning documents. A specialist company is a company that is familiar with the installation and maintenance of photovoltaic systems as part of its normal business operations. National and local building regulations, standards and environmental protection must be complied with. Under no circumstances may the assembly personnel be under the influence of medication, alcohol, drugs or in any other condition that impairs consciousness (e.g. overtiredness). Trainee personnel may only carry out work under the instruction and supervision of specialist personnel who are authorized to train personnel.

WORKING SAFELY

The contractual partner shall ensure that all relevant safety and labor regulations are complied with during installation. Information from AEROCOMPACT Europe GmbH is supportive, but without guarantee or claim to completeness. The contractual partner is responsible for informing himself about all applicable regulations and implementing them. Areas below the roof must be protected from falling objects and blocked off if necessary. Work must not be carried out in unsuitable weather conditions, strong winds, wet conditions or temperatures below freezing. Only use intact, tested ladders and secure them. Mechanical climbing aids have their own rules and the PV mounting system must not be used as a climbing aid. Maintain a distance from overhead power lines and carry out equipotential bonding in accordance with country-specific regulations. When cutting materials to size, ensure that there are no burrs, especially on edges and corners. Rooflights, skylights and large ventilation flaps do not generally bear the load of people. Secure these areas such as roof edges. Corrugated fiber cement roofs are generally susceptible to breakthrough. Define routes and secure them with load distribution. Always use load distribution aids on non-load-bearing roof coverings (e.g. thin sheet metal, corrugated fiber cement).

PERSONAL PROTECTIVE EQUIPMENT (PPE)

Personal protective equipment is used to protect people from health and safety hazards at work. Personnel must wear personal protective equipment during installation. Personal protective equipment is explained below:



Wear safety goggles when drilling and sawing



Wear cut-resistant work gloves during assembly



Wear safety shoes



Use fall protection



Helmets must be worn by all persons working on the construction site



Wear hearing protection

STRUCTURE OF THE WARNINGS ACCORDING TO HAZARD LEVELS

The warnings used in these installation instructions indicate safety-relevant information. They consist of:

- > Signal word and warning sign to indicate the hazard level
- > Type and source of danger
- > Consequences of ignoring the danger
- > Escape (measures to avoid the danger)

WARNING SIGNS ACCORDING TO EN ISO 7010 - EXAMPLES



SIGNAL WORDS ACCORDING TO EN IEC/IEEE 82079

Personal injury

Indicates an imminently hazardous situation which, if not avoided, will result in death or serious injury.

Personal injury

Indicates a potential hazard which, if not avoided, will result in death or serious injury.

Personal injury

Indicates a potential hazard which, if not avoided, will result in death or serious injury.

Material damage

Indicates a situation which, if not avoided, may cause damage to the product or other property.



i The information given here on warning signs covers the minimum requirements. However, there may be additional national, regional or project-specific requirements that must also be fully observed. Compliance with all relevant regulations is essential.

SYSTEM OVERVIEW

SN2 PLUS 10°

CLAMPING TYPE: LONG SIDE CLAMPING

DESIGN: CONNECTED BASE RAILS

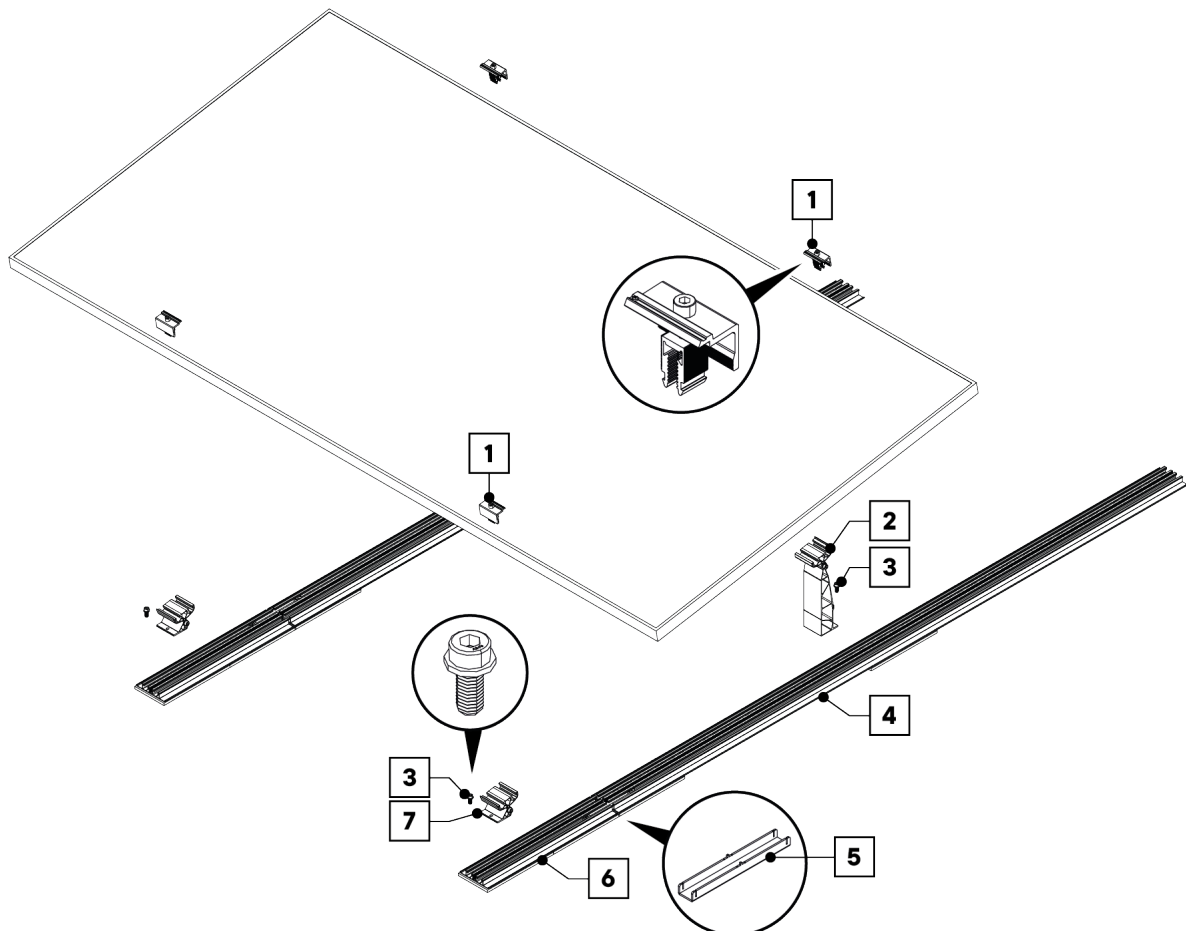

1 CLE20

End clamp Click 28 - 42 mm

3 AB8x18S

Allen head bolt M8x18 serration

5 BRCNSN

Base rail connector SN

7 SNLSFB

SN Front bracket Landscape

2 SNLS10RB

SN rear bracket landscape 10°

4 BR1980 | BRW1980

Base rail 1980 mm | Base rail wide 1980 mm

6 BR450 | BRW450

Base rail 450 mm | Base rail wide 450 mm

CLAMPING TYPE: LONG SIDE CLAMPING
DESIGN: LONG BASE RAILS

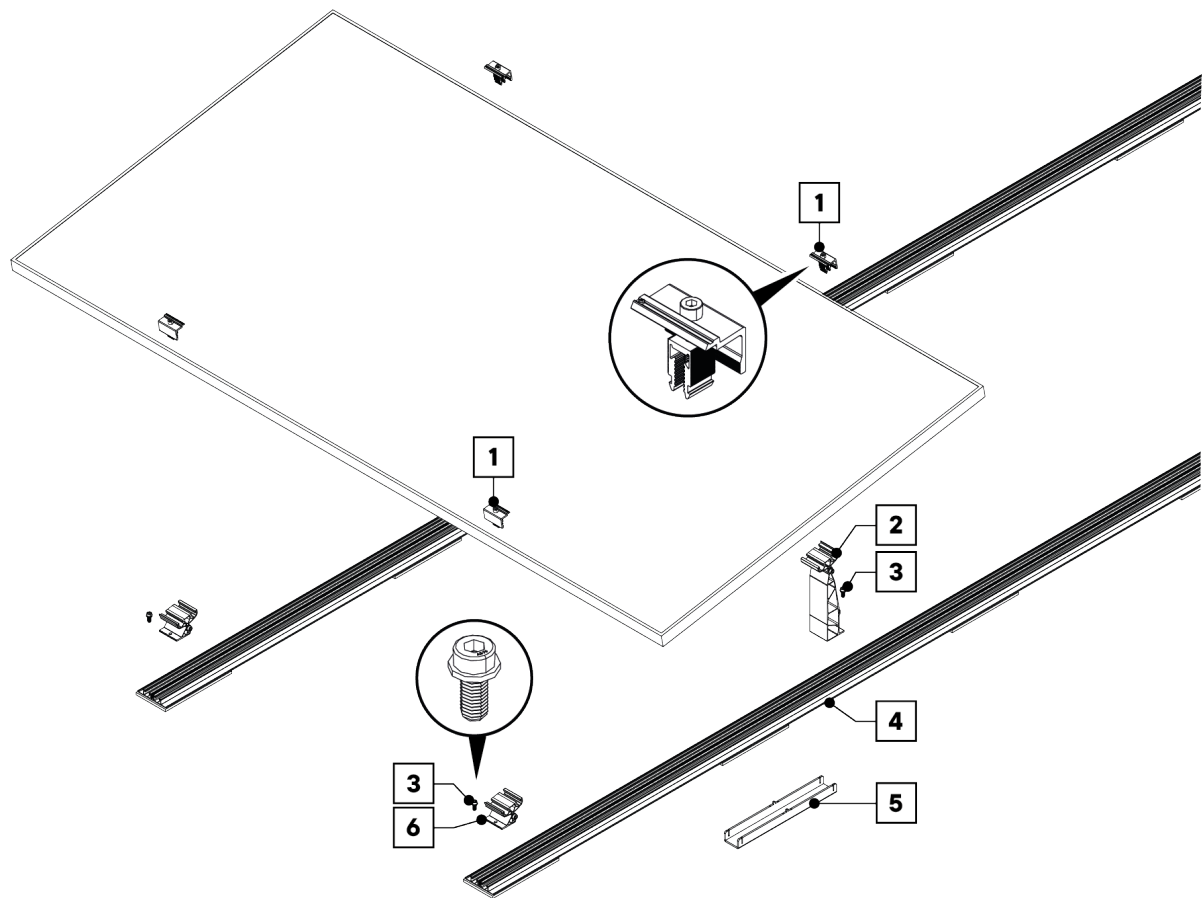

- 1 CLE20**
End clamp Click 28 - 42 mm
- 3 AB8x18S**
Allen head bolt M8x18 serration
- 5 BRCNSN**
Base rail connector SN

- 2 SNLS10RB**
SN rear bracket landscape 10°
- 4 BR5800**
Base rail 5800 mm
- 6 SNLSFB**
SN Front bracket Landscape

SN2 PLUS 5°

CLAMPING TYPE: LONG SIDE CLAMPING
DESIGN: CONNECTED BASE RAILS

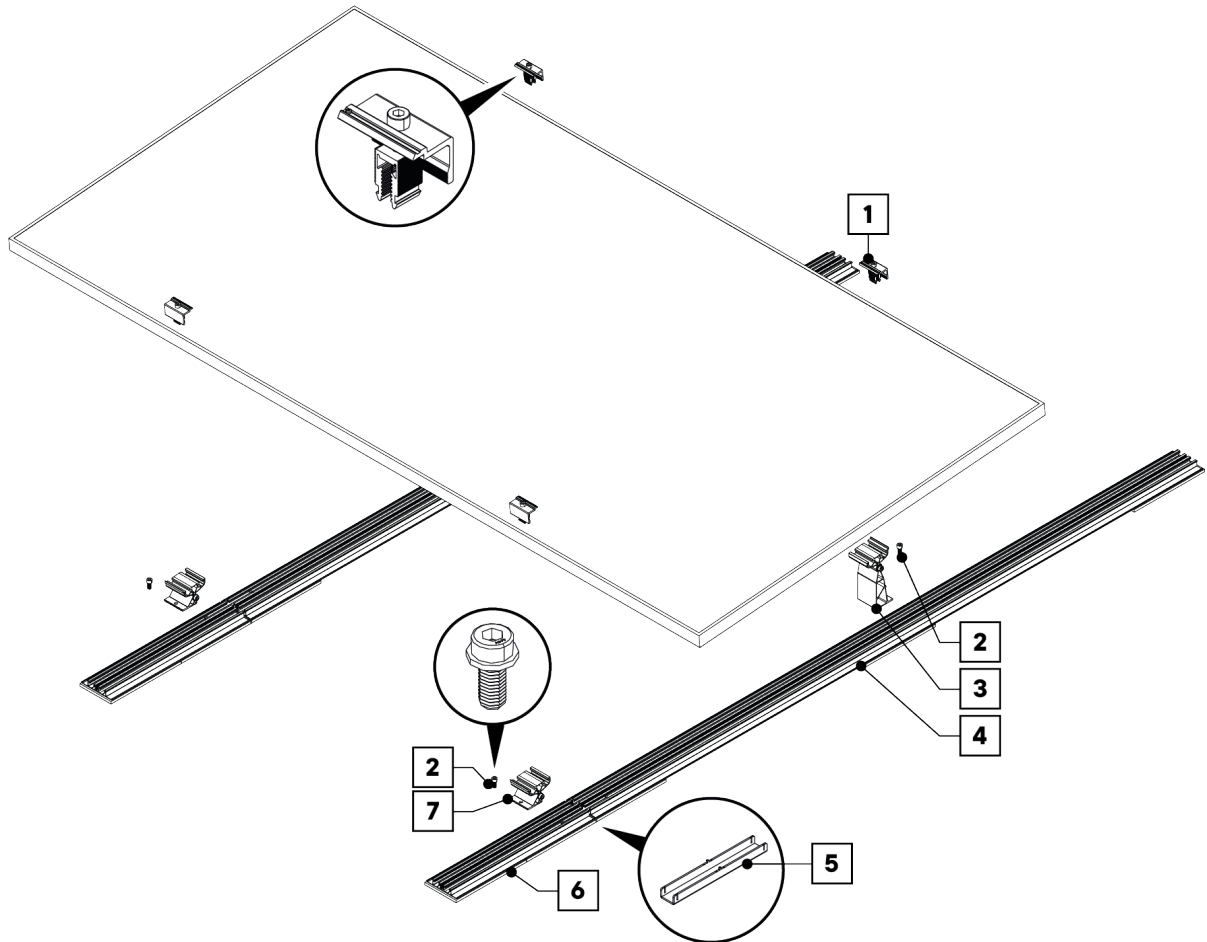

1 CLE20

End clamp Click 28 - 42 mm

3 AB8x18S

Allen head bolt M8x18 serration

5 BRCNSN

Base rail connector SN

7 SNLSFB

SN Front bracket Landscape

2 SNLS05RB

SN rear bracket landscape 5°

4 BR5800

Base rail 5800 mm

6 BR450 | BRW450

Base rail 450 mm | Base rail wide 450 mm

CLAMPING TYPE: LONG SIDE CLAMPING
DESIGN: LONG BASE RAILS

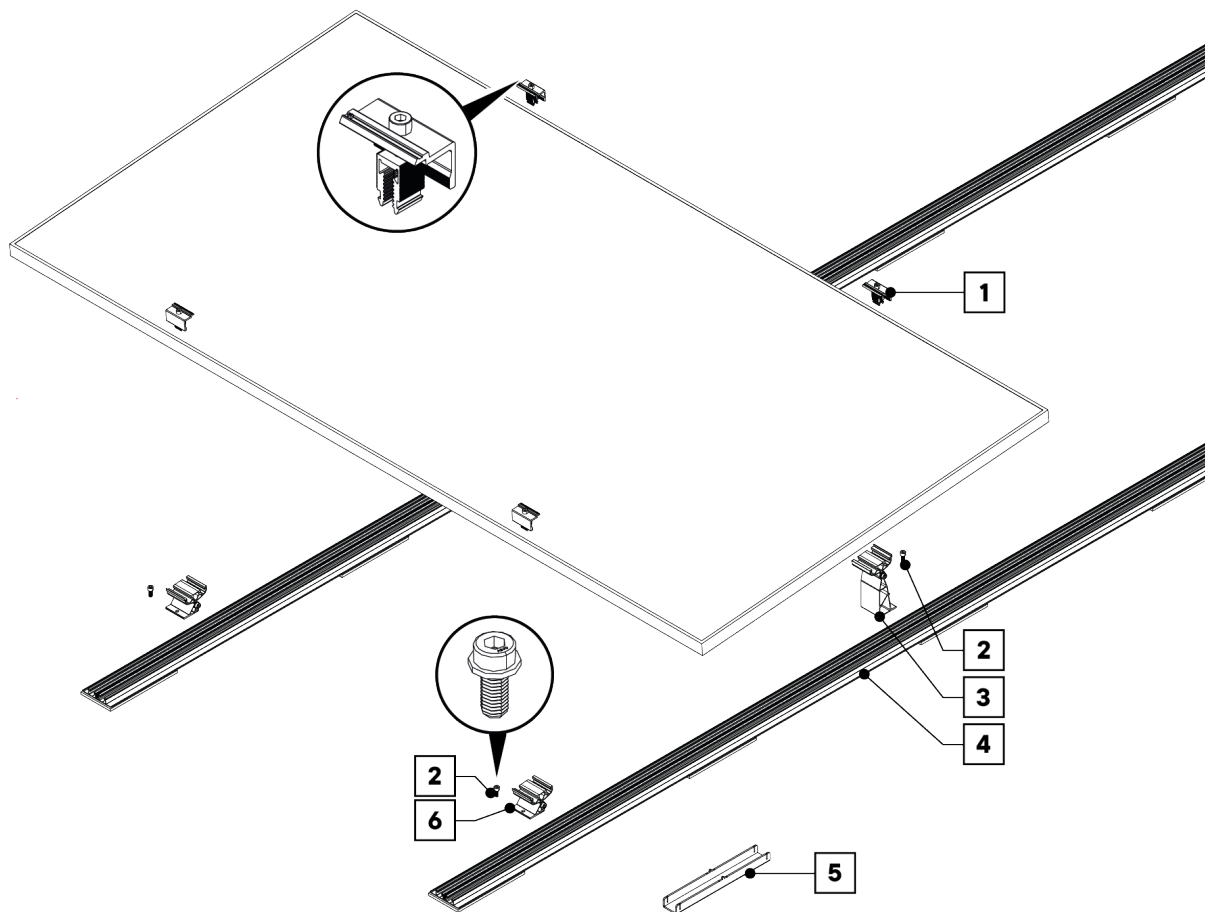

- 1 CLE20**
End clamp Click 28 - 42 mm
- 3 SNLS05RB**
SN rear bracket landscape 5°
- 5 BRCNSN**
Base rail connector SN

- 2 AB8x18S**
Allen head bolt M8x18 serration
- 4 BR5800**
Base rail 5800 mm
- 6 SNLSFB**
SN Front bracket Landscape

SYSTEM ACCESSORIES



SN-SP-1980
SN2 Mounting gauge for front brackets and rear brackets 1980 mm

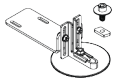

APA-SN
Single roof anchor connection for SN2



BIT150E
Bit extension 150 mm



SN-SP-2500
SN2 Mounting gauge for base rails 2500 mm

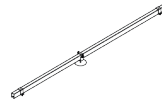

DAPA
Double roof anchor connection with anchor rail 1280 or 2500 mm

BALLASTING ACCESSORIES



CSo-XXXX
Cross strut outer part 990 mm, 1150 mm, 1290 mm, 1380 mm



CSi-XXXX
Cross strut inner part 990 mm, 1150 mm, 1290 mm, 1380 mm



MSS6x25
Thin sheet metal screw 6x25



AB8x18S
Allen head bolt M8x18 serration

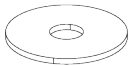

FW8.4/24
Washer 8,4x24

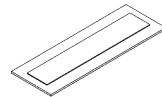

PP200
Building protection pad for ballast stones and ballast tray

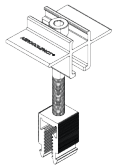

CLB20
Ballast clamp for ballast stone height from 40 - 80 mm

CABLE MANAGEMENT

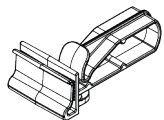

CLP-U
Cable clip universal

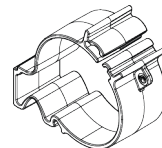

SNCLP-R
Cable clip SN2 rail

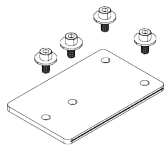

SNCP125
Connecting plate BR125x80

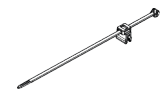

CLP-M
Cable tie clip for module frames with a thickness of 1 - 3 mm

EQUIPOTENTIAL BONDING ACCESSORIES

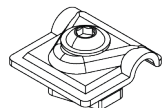

WCL8-10
Wire clamp 8 - 10 mm

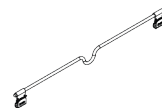

BJ8
Earthing jumper 200 mm (UL 467 and UL 2703 compliant)

ASSEMBLY

ASSEMBLY PREPARATION

Required tools for assembly

i Before starting the assembly, make sure that the assembly personnel are familiar with the proper use of the listed tools.



Bit hexagon socket 6 mm



Bit TORX T40



Measuring tape



Chalk line



Torque wrench 10 - 30 Nm with hexagon socket bit 6mm



Cordless screwdriver



Socket bit 8 mm

INFORMATION ON MOUNTING ON GRAVEL ROOFS

i According to the planning documents, the installation of the system takes place either directly on the seal or the protective fleece (coefficient of friction 1.5) or freely on the gravel (coefficient of friction 0.3).

Install the system on waterproofing or protective fleece

✓ Height of gravel fill: 30 - 60 mm

i Due to possible damage to the roof waterproofing caused by excessive linear/surface loads, it is not recommended to install the system on a gravel layer of less than **60 mm**.

- ▣ Carefully remove the gravel in the area of the module field.
- ▣ Install the system directly on the waterproofing or on the protective fleece.

Set up the system on the gravel

- ✓ The height of the gravel bed is 60 – 100 mm and protective fleece (min. 300 g/m²) is available or
- ✓ the gravel fill is 100 mm or more.

▣ Place the system on the gravel.

WIDE BASE RAILS

i The wide base rail is suitable for optimum **load distribution** with soft roof insulation.

VARIANTS



BRW450

Base rail wide 450 mm



BRW1980

Base rail wide 1980 mm

DIMENSION



i The wide base rail is available in lengths of **450 mm** and **1980 mm**.

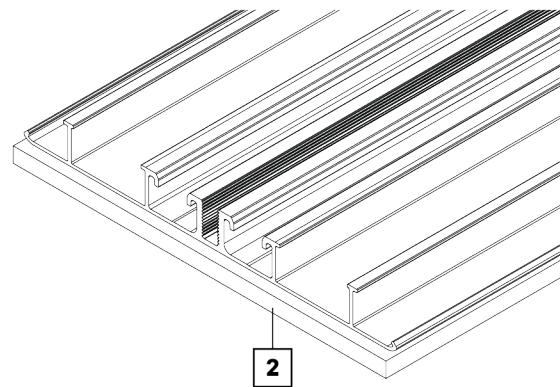
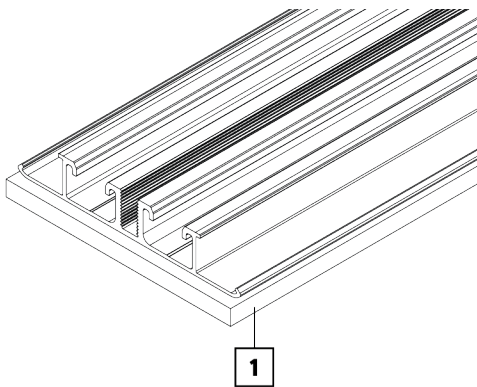
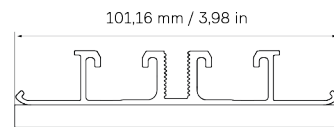
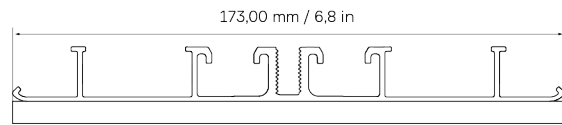

i Info:

The installation sequence in these instructions is identical for the standard base rail (1) and the wide base rail (2). The SN2 components are compatible with both base rails*.

*The single roof anchor connection is not compatible with the wide base rail.

MEASURE THE MODULE FIELD

i Important:

Before starting installation, compare the dimensions of the module array and the distances to the edge of the module array with the **planning documents** to ensure correct installation.

DISTANCE BASE RAILS

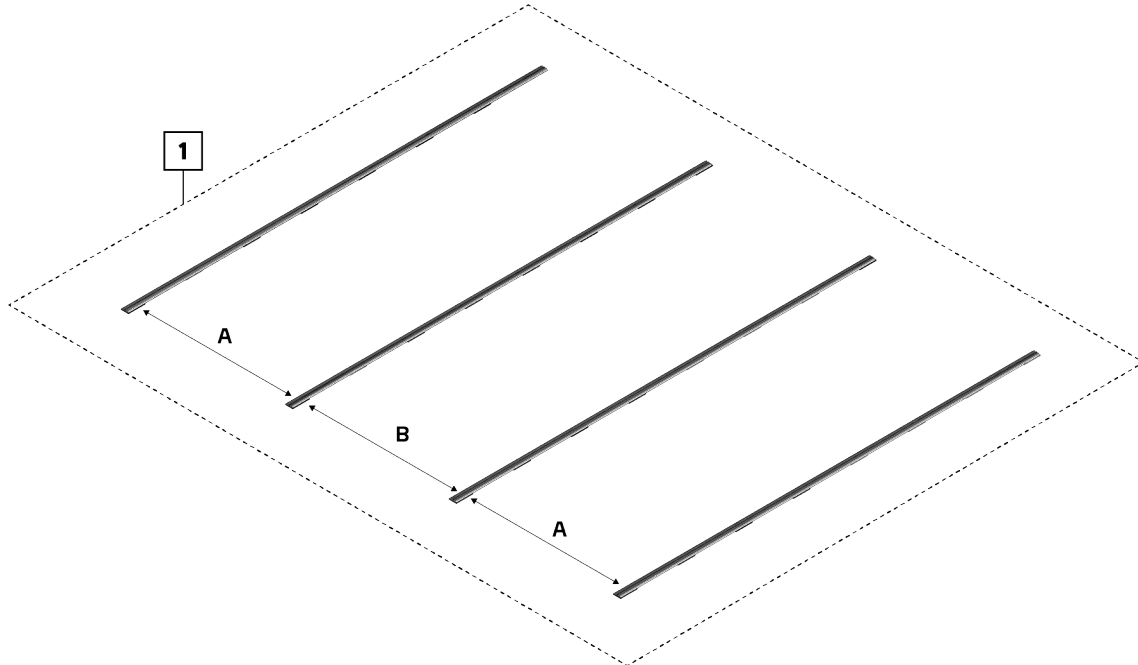

- Measure and mark the distance from the first base rail to the edge of the module field (1).
- Measure the distances between the base rails: **A = 1/2 of the module length** | **B = 1/2 of the module length + 2 cm** and mark.

i Attention:

- Observe the module manufacturer's clamping specifications
- Note the length of the cross struts



A mounting gauge is available as an optional accessory for positioning the base rails. The instructions for this can be found in the "SN2 assembly gauge" chapter.

BASE RAIL CONNECTOR

i Two base rails are connected using the base rail connectors. Due to thermal expansion, it is essential to install the base rail connectors in a **floating position**.

REQUIRED COMPONENTS

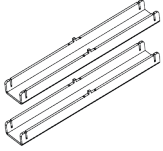

BRCNSN
Base rail connector SN

ASSEMBLY



> Insert the two base rail connectors (1) at the base rail (2).

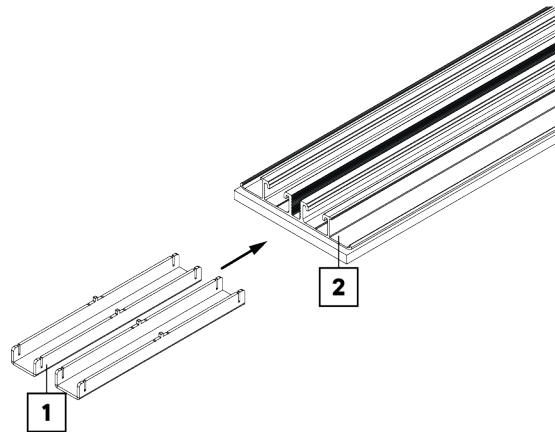

i The base rail connector has a notch (1) on both sides. This marks how far the connector must be pushed in.

> Insert the base rail connectors up to the notch (1).

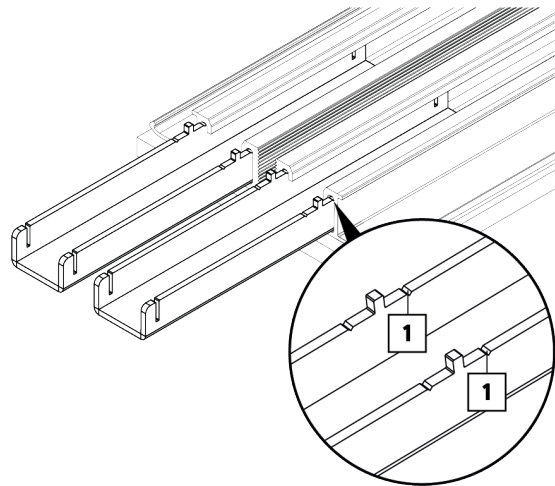

i The base rail connectors must **not** be screwed together!

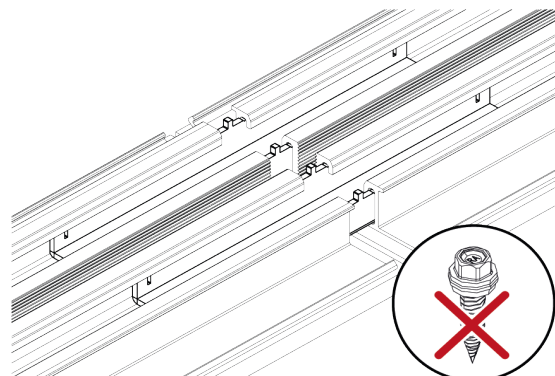

ATTACH ADDITIONAL STRUCTURAL PROTECTION PADS (OPTIONAL)

i Taking into account the structural conditions, it is necessary to improve the bearing surface of the system. For this purpose, additional structural protection pads are installed, the number of which must be taken from the planning documents. The possibility of pre-assembly of the building protection pads exists.

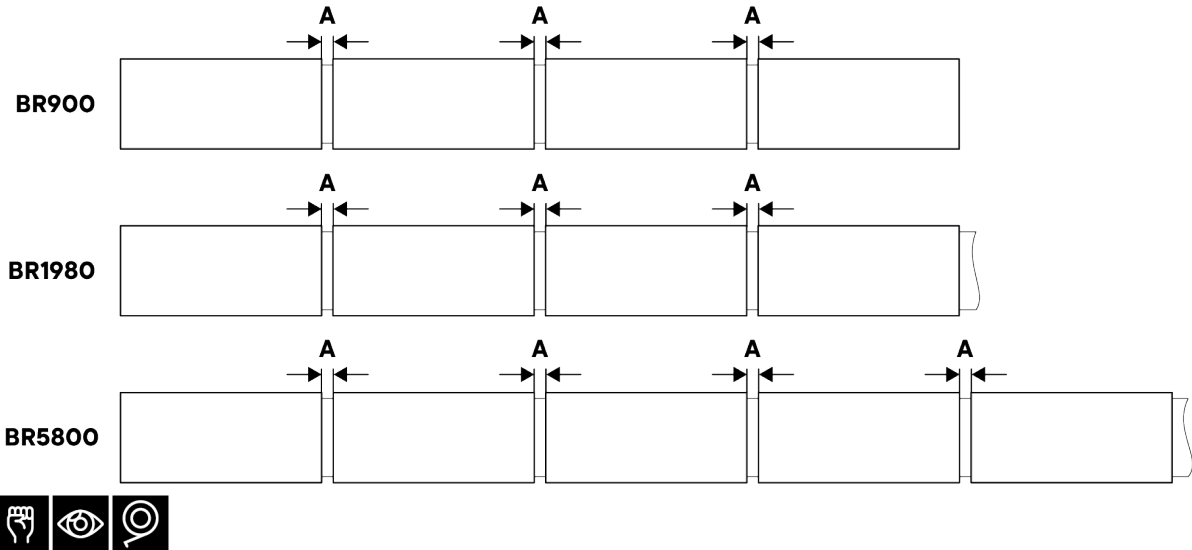

⊗ It is important to ensure that the distance (A) between the construction protection mats is always even, and that the area to be covered with the base rail is dry and free of grease, dust or other contamination.

⊗ The number of structural protection mats is defined by the length of the base rails:

- BR900** Two additional protection pads per rail
- BR1980** Two additional protection pads each between the existing protection pads
- BR5800** Three additional protection pads each between the existing protection pads

Attach construction protection mats to cut-to-size base rails

i The base rails (BR5800) can be cut/separated for the following reasons: firstly, for thermal separation according to the planning documents; secondly, if the base rails protrude beyond the module field. To secure the roof cladding, structural protection pads are placed underneath the base rails at the separation points. If a construction protection pad is already present at a separation point, it is removed.

DANGER	
	<p>Danger from cuts</p> <p>Skin contact with sharp edges can cause cuts.</p> <ul style="list-style-type: none">➤ Wear safety gloves➤ Handle with care

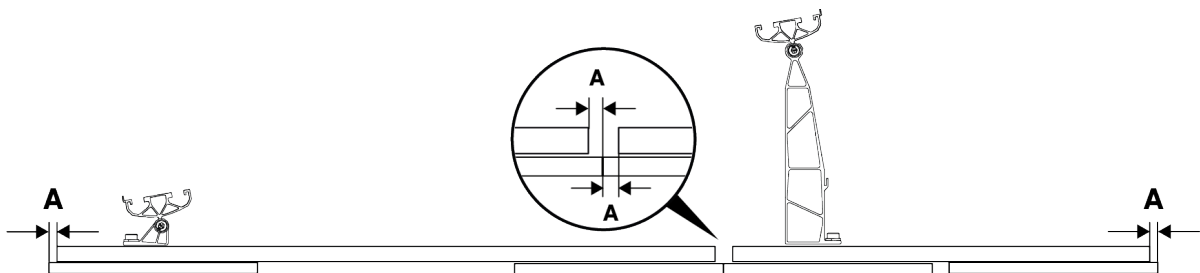

➤ It is necessary to place construction protection pads at the ends of the base rails. The overhang of the building protection pads is **A = 6 mm** in each case.

Protection pads for level compensation

i If the surface is uneven, additional building protection pads can be placed underneath to level it out.

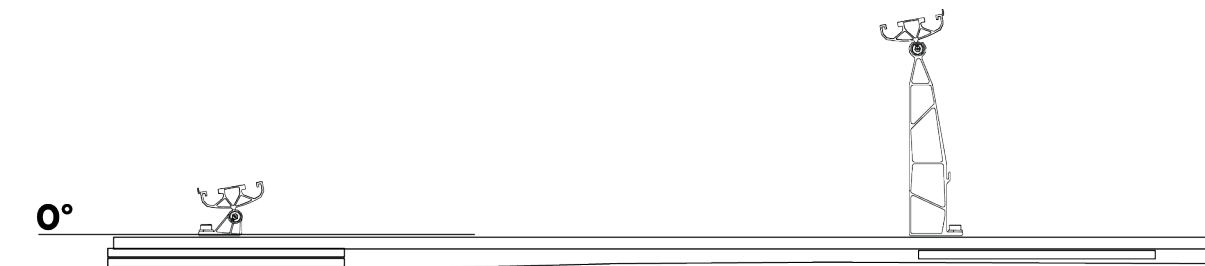

➤ Place the required protection pads under the base rail until an angle of **0°** is achieved.

SN2 MOUNTING GAUGE

Positioning the base rails

REQUIRED COMPONENTS

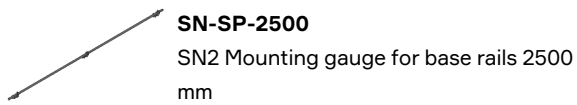

INSERT SPACER



- Insert **3 pcs.** spacers (2) into the guide rail (1).
- Then mount the end cap (3).

i When inserting the spacers, make sure that the sliding block is positioned correctly (see illustration).

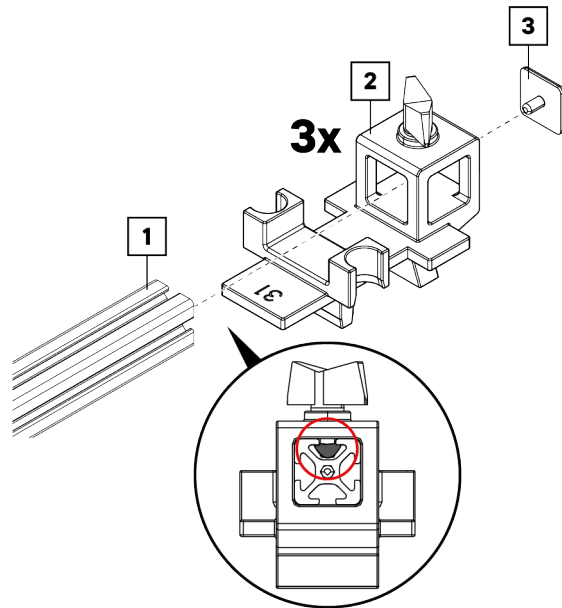

POSITIONING THE SPACER

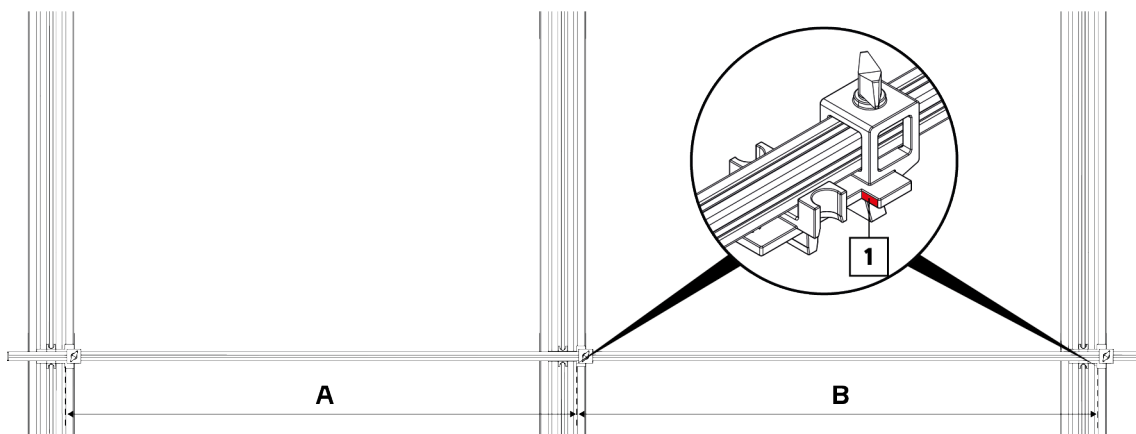

- When measuring, ensure that the **same point** (1) is measured for each spacer.
- Distribute and measure the spacers. **A = 1/2 of the module length** | **B = 1/2 of the module length + 2 cm**
- Then tighten the locking screw.

i Attention:

- Observe the module manufacturer's clamping specifications
- Note the length of the cross struts

USE MOUNTING GAUGE



- ✓ The mounting gauge is now prepared for the placement of the base rails and can be positioned as shown in the illustration.

i Place the mounting gauge horizontally along the base rails several times to ensure **parallelism**.

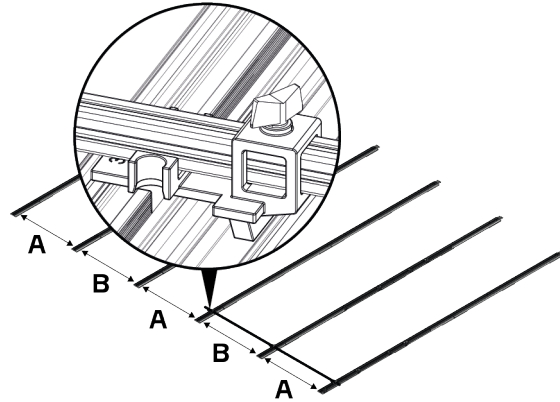

Position brackets.

REQUIRED COMPONENTS



SN-SP-1980

SN2 Mounting gauge for front brackets and rear brackets 1980 mm

INSERT SPACER



- Insert **4 pcs.** spacers (2) into the guide rail (1).
- Then mount the end cap (3).

i When inserting the spacers, make sure that the sliding block is positioned correctly (see illustration).

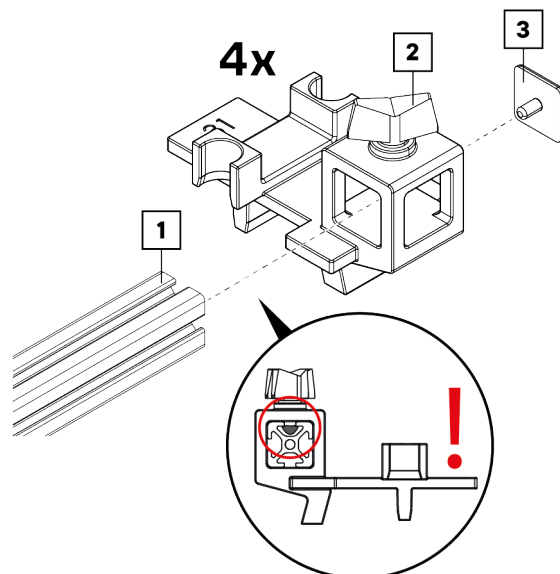

POSITIONING THE SPACER

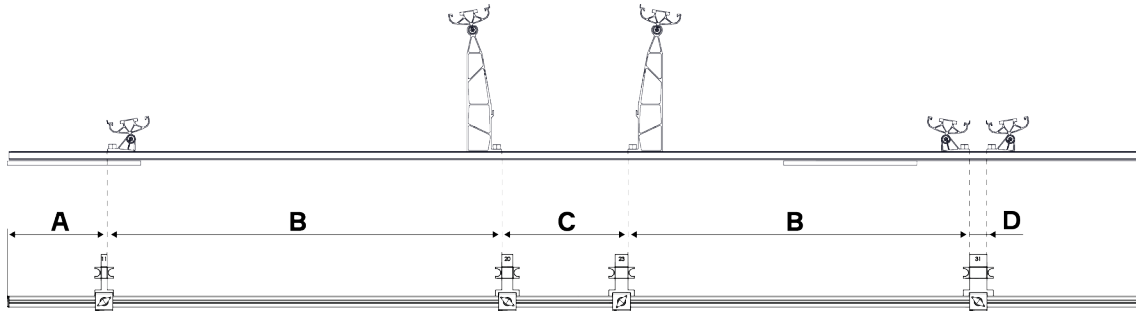

- ▶ Take the dimensions **A**, **B**, **C** and **D** from the planning documents.
- ▶ Measure the spacers and position them as shown in the illustration.

FIXING SPACER



- ▶ After positioning, tighten the spacers with the locking screw (1).

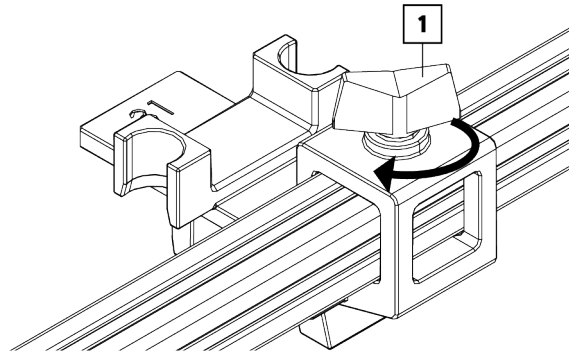

MOUNT BRACKET



EXAMPLE FRONT BRACKET (SNLSFB)

- ▶ Place the bracket to the mounting gauge and mount it.

i The steps for assembly the brackets can be found in the "Fitting the feet" section.

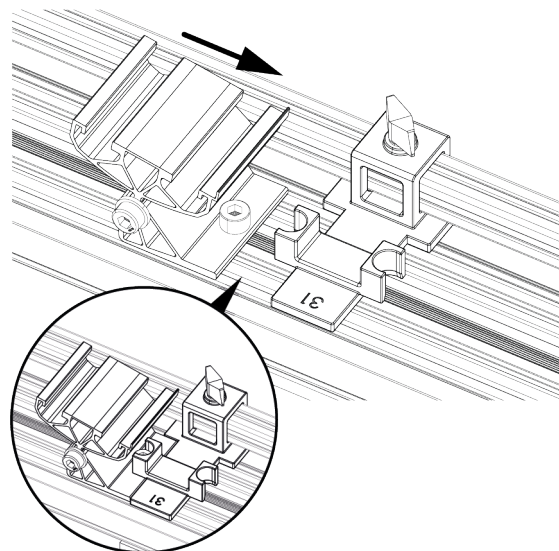

MOUNT BRACKETS

Mount front bracket

REQUIRED COMPONENTS



SNLSFB
SN Front bracket Landscape

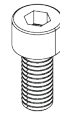

AB8x18S
Allen head bolt M8x18 serration



- ▶ Mount the front bracket (south side) on a BR450 base rail.
- ▶ Tilt the bracket rocker backwards as shown in the illustration.
- ▶ Then tighten the screw (2) with a torque of 15 Nm or 11 lb-ft.

i Important!

Never use an impact or impulse wrench when installing the components. The use of a bit extension is recommended for fastening the bracket.

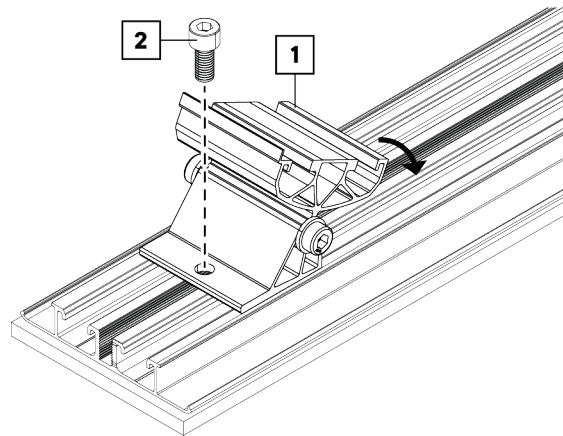

Mount rear bracket 5°

REQUIRED COMPONENTS



SNLS05RB
SN Rear Bracket Landscape 5°

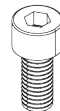

AB8x18S
Allen head bolt M8x18 serration



BIT150E
Bit extension 150 mm



- ▶ Position the rear bracket (1) on the base rail.
- ▶ Tilt the bracket rocker backwards as shown in the illustration.
- ▶ Then tighten the screw (2) with a torque of 15 Nm or 11 lb-ft.

i Important!

Never use an impact or impulse wrench when installing the components. The use of a bit extension is recommended for fastening the bracket.

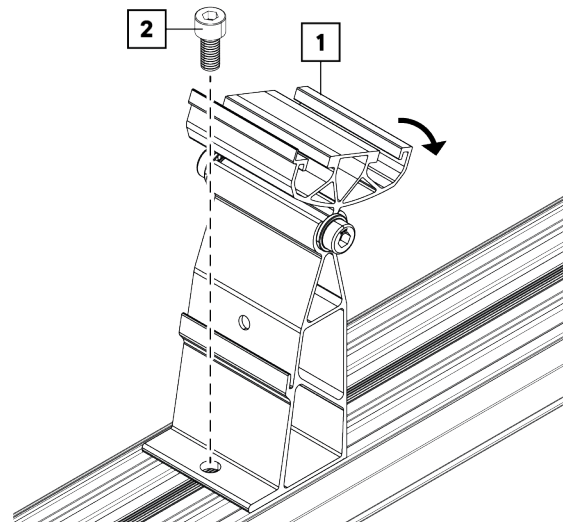

Mount rear bracket 10°

REQUIRED COMPONENTS



SNLS10RB
SN Rear Bracket Landscape 10°

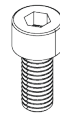

AB8x18S
Allen head bolt M8x18 serration

BIT150E
Bit extension 150 mm



- Position the rear bracket (1) on the base rail.
- Tilt the bracket rocker backwards as shown in the illustration.
- Then tighten the screw (2) with a torque of 15 Nm or 11 lb-ft.

i Important!

Never use an impact or impulse wrench when installing the components. The use of a bit extension is recommended for fastening the bracket.

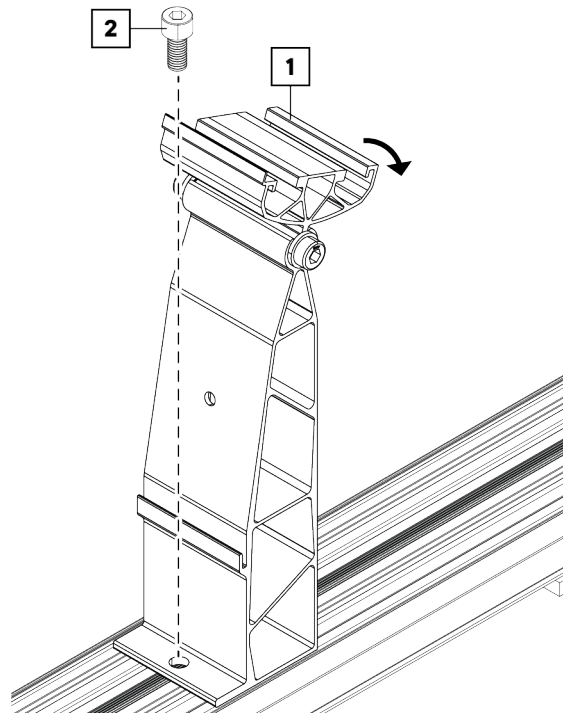

INSTALLATION IN THE JOINT AREA OF THE BASE RAILS



- i** For connected base rails, make sure that the brackets are not screwed in the joint area between two base rails. A distance of at least **A = 20 mm** must be maintained from the joint area.

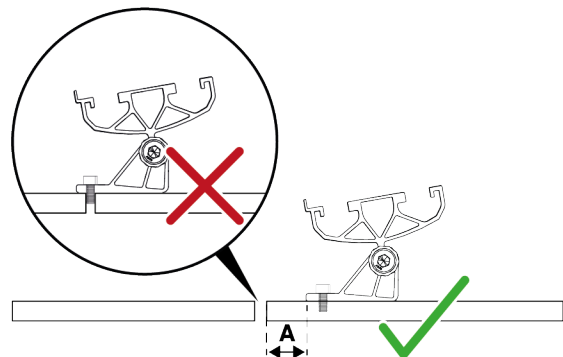

Variants

i The following variants apply to both the **5° system** and the **10° system**; the work steps are identical.

CONNECTED BASE RAIL

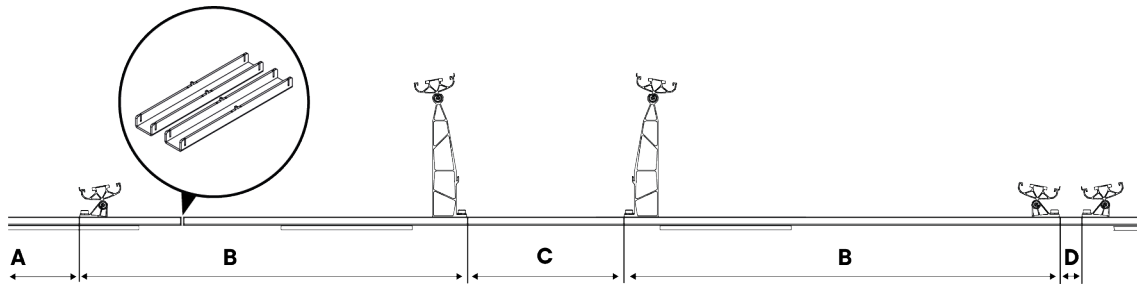

LONG BASE RAIL

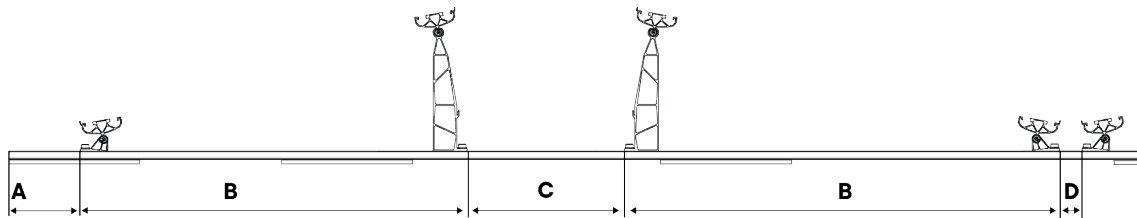

An assembly gauge is available as an optional accessory for positioning the front bracket and rear bracket. The instructions for this can be found in the chapter "SN2 Mounting gauge" on page 19.

i Important!

Never use an impact or impulse wrench when installing the components. The use of a bit extension is recommended for fastening the bracket.

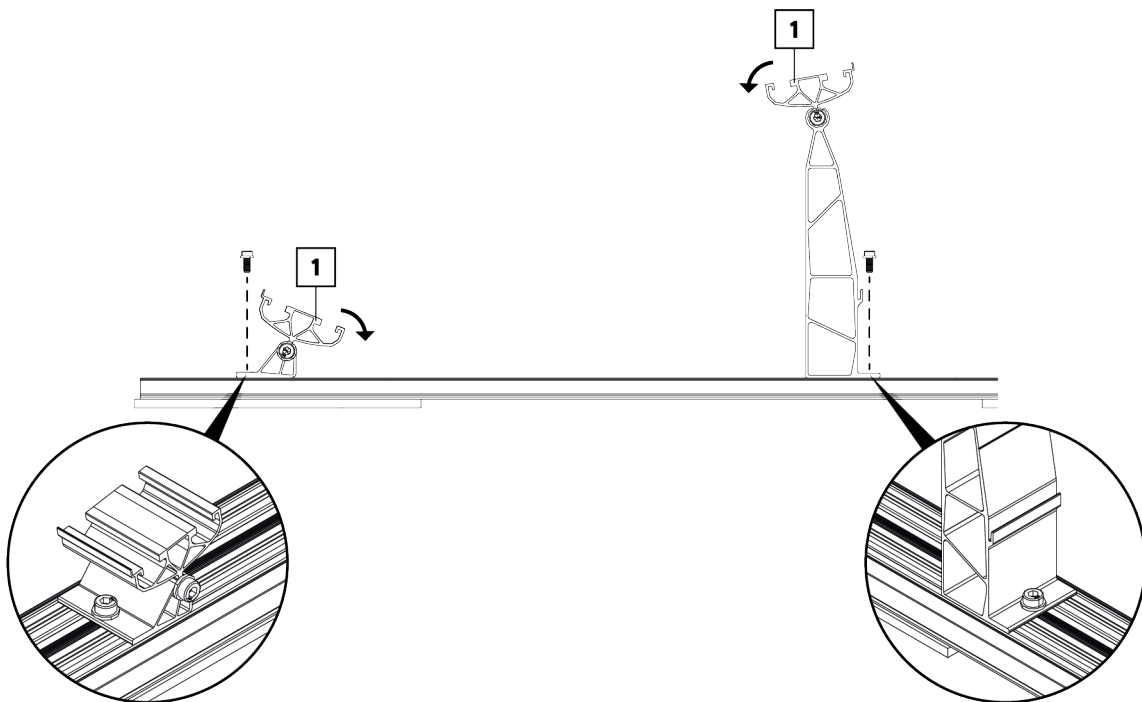

- Position the brackets at the determined positions on the base rail and tighten the Allen screw.
- Tilt the bracket rocker (1) as shown in the illustration.
- Then tighten the Allen screw to a torque of 10 Nm or 7.38 ft-lb.

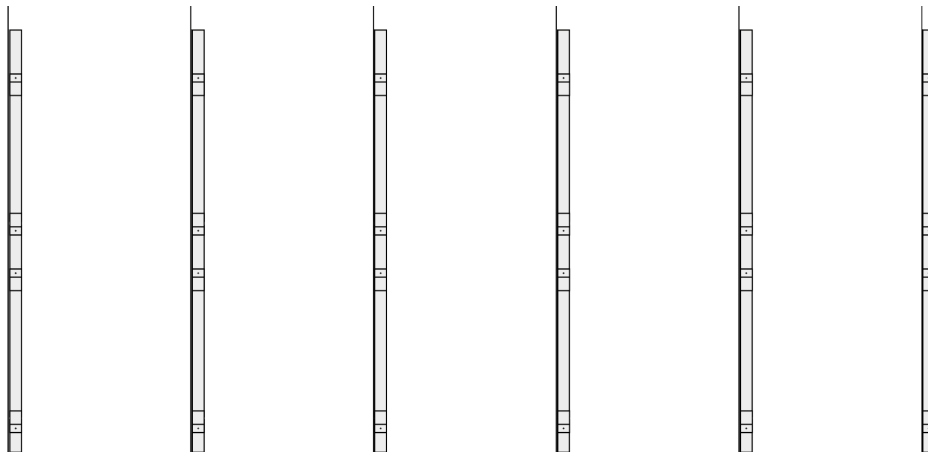

- Then align the pre-assembled base rails to the marked positions.

MOUNT MODULES

i The assembly of the modules begins in the southernmost row.



➤ Attach an end clamp to the front bracket in the outer clamping channel.

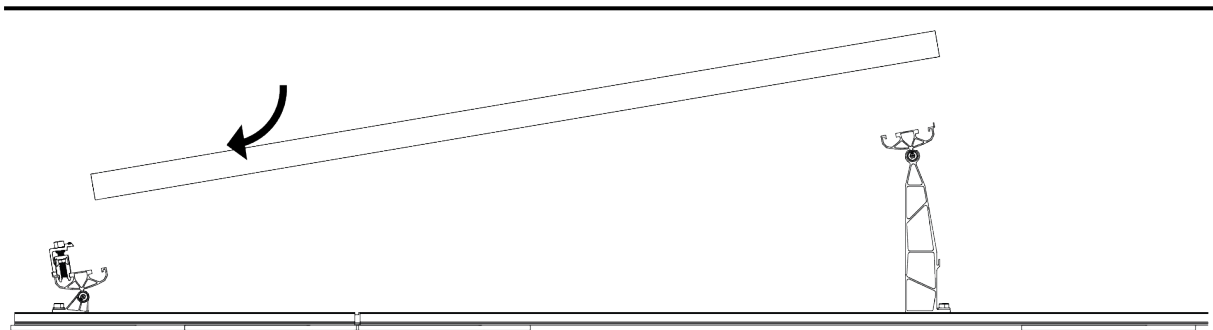
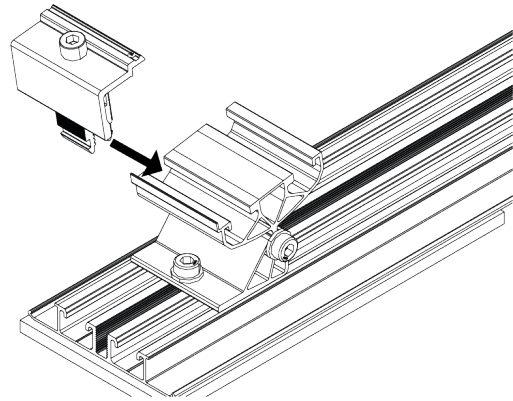

➤ Place the module on the bracket: Place the module flush against the clamps.

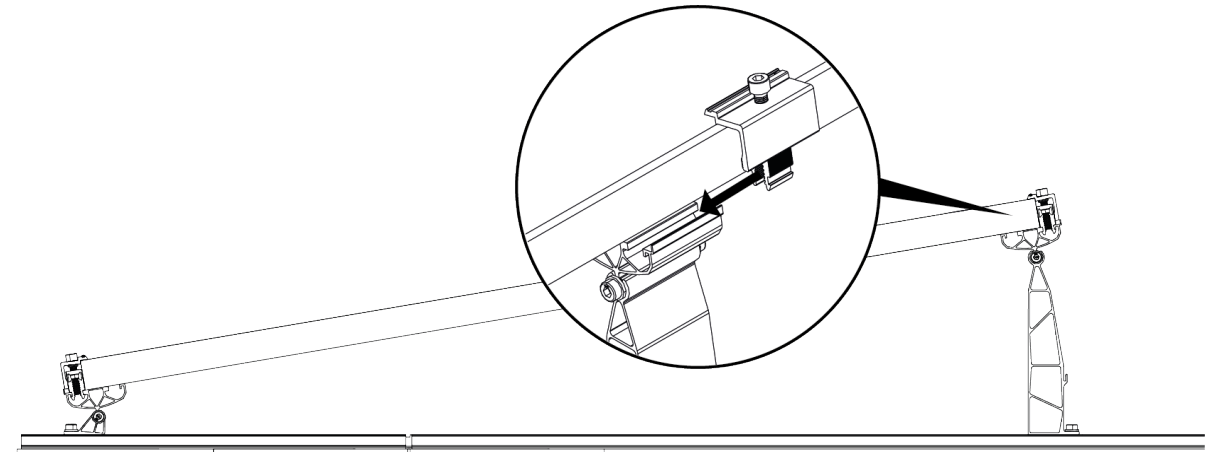

➤ Attach end clamps to the rear bracket.

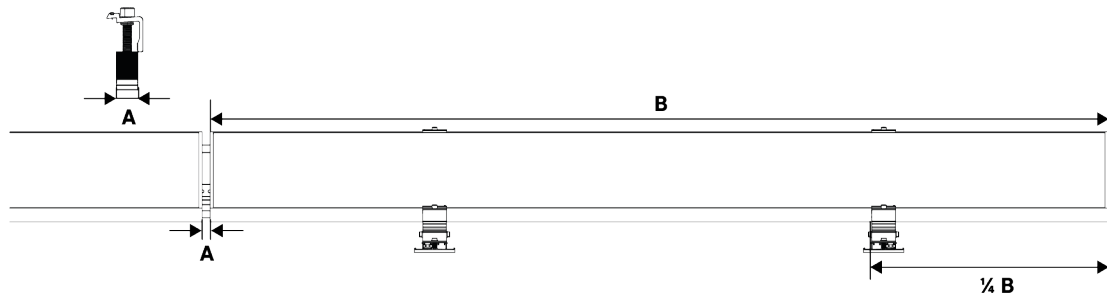

i The distance (A) between the modules is 2 cm. As an aid, 2 clamps can be used as gauges.

Position of the clamps: according to the module manufacturer's recommended clamping position, if permissible $\frac{1}{4}$ of the module length B, measured from the respective module edge.



- Lay the modules row by row.
- Align the rail lines if necessary.

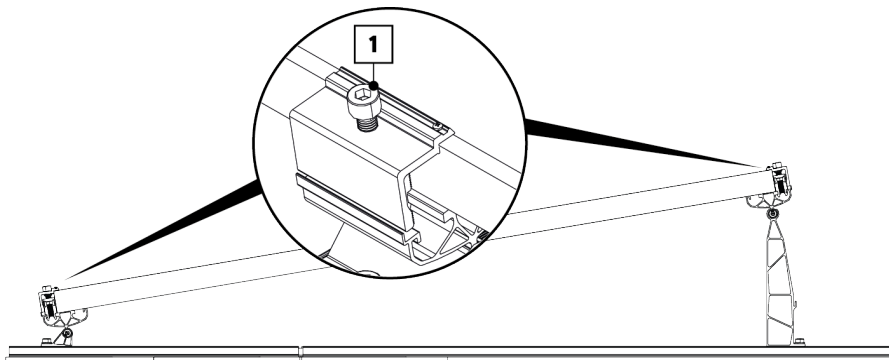
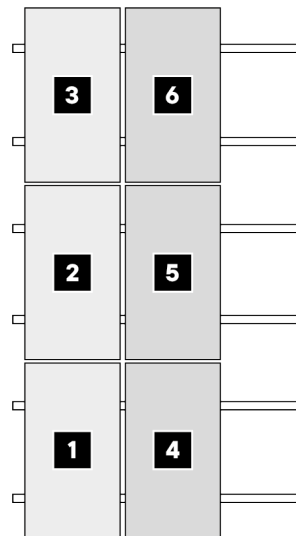

- Tighten the screws on the end clamps to 15 Nm or 11 ft-lb.

REPOSITION / REPLACE CLAMPS

- Dismantle the mounted clamp: Unscrew the screw on the clamp completely.
- Depending on the installation situation, press the clamp together at the side and pull it out or pull it out of the rail at the side.

BALLASTING

i Depending on the circumstances, the system can be ballasted in various ways. The exact number and position of ballasts are specified in the planning documents.

REQUIRED COMPONENTS

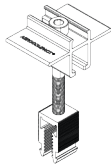

CLB20

Ballast clamp for ballast stone height from 40 - 80 mm

Ballast clamp

MOUNT BALLAST CLAMP



- Click the ballast clamp (1) onto the side of the ballast block.

i Important!

During installation, ensure that the ballast clamp (1) is in contact with the ballast block to prevent the ballast clamp from twisting.

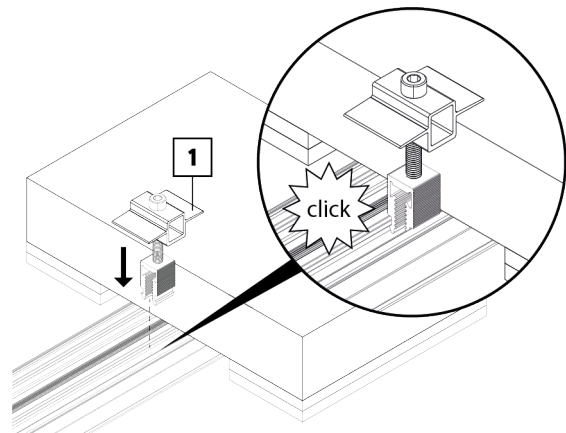

PLACE BALLAST BLOCKS

i The ballast clamp can be used to attach up to **two** ballast blocks. It is possible to arrange several ballast blocks on top of each other. From the **third layer** onwards, secure fastening is the responsibility of the **specialist personnel**.

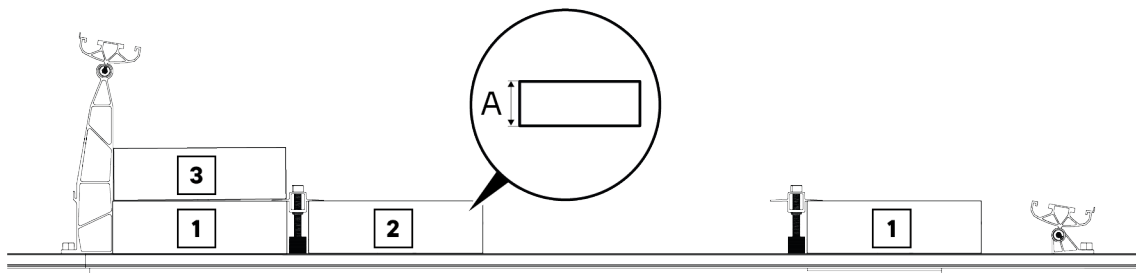

i The ballast clamp is designed for ballast blocks with a height of **A = 40 - 60 mm** suitable.

- Place the ballast blocks (1-2) in accordance with the planning documents.
- Tighten the ballast clamps to a torque of 15 Nm or 11 lb-ft.
Important: Make sure that the wings of the ballast clamp are flush with the ballast blocks.
- Place the other ballast blocks (3) on top.

Positioning the ballast

CONNECTED AND LONG BASE RAIL VARIANT

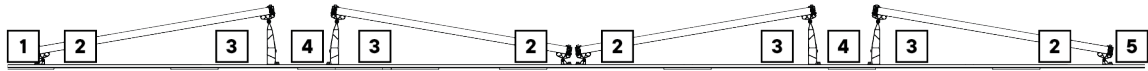

The ballast can be placed in the following positions:

- | | |
|--|---|
| 1 in front of the module (south side) | 2 under the module (module bottom) |
| 3 under the module (module top) | 4 between the module rows |
| 5 behind the module (east side) | |

CROSS STRUTS

i Depending on the planning variant, the cross struts are used for the following purposes:

- Connection of the base rails with pre-assembled option
- Connection of the module rows
- Fix ballast
- Bonding purposes

Possible mounting positions of the cross struts

i The position and number of cross struts in the module field can be seen in the planning documents.

L Cross struts is used to fix ballast

L Cross strut is used for joining, connecting the base rails as well as bonding purposes and/or fixing the ballast

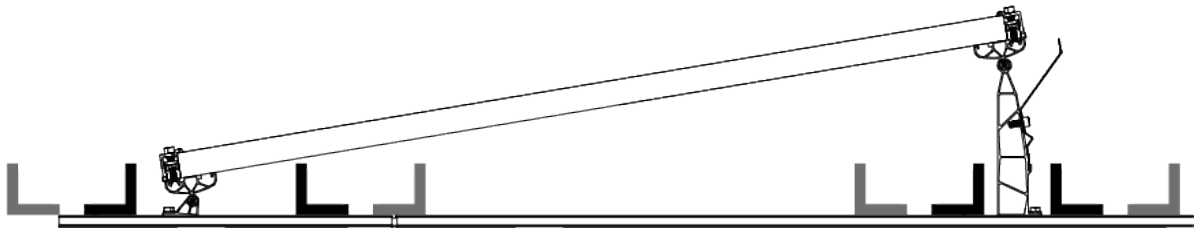

Mounting the cross-member with preassembled option

i The preassembled option is only possible for connected and long base rails.

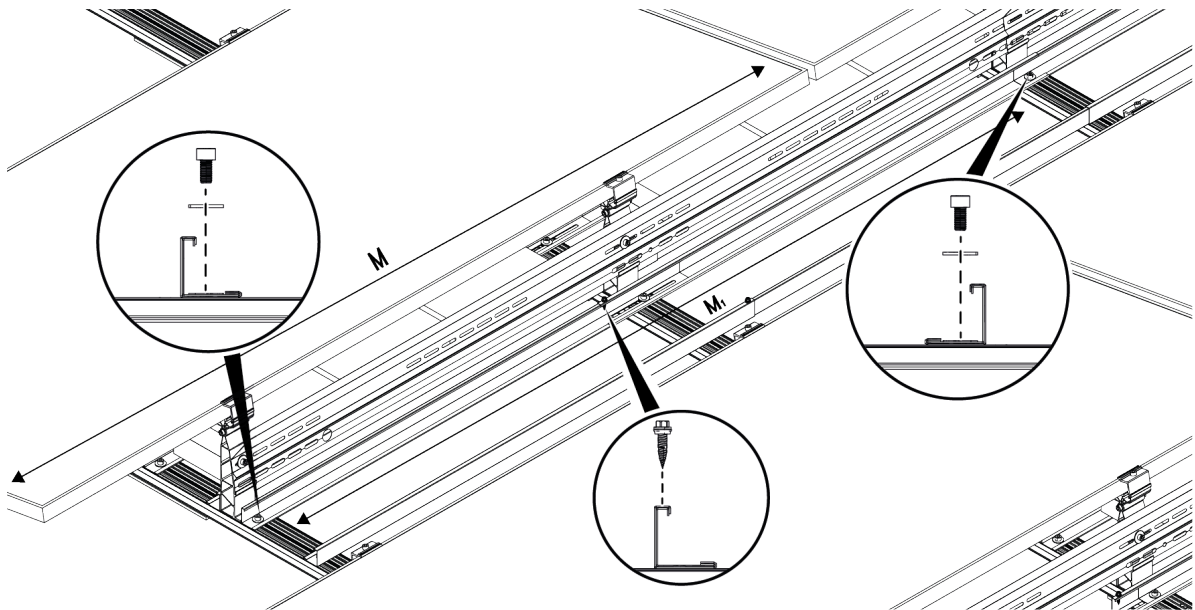

- Slide the outer part and inner part of the cross struts into each other.
- Determine dimension M = module length.
Dimension M_1 = module length + 20 mm
- On the cross struts, measure the dimension M_1 from the center of the bore.
- Connect the inner part and outer part of the cross-members with a thin sheet metal screw.
- Screw the cross-member with Allen screw (AB8x18S) and washer to the base rail.

Connect module rows

i In order to obtain a connection between the module rows, cross-member outer parts are used. The exact number and position of the connections with the cross-members can be found in the planning documents.

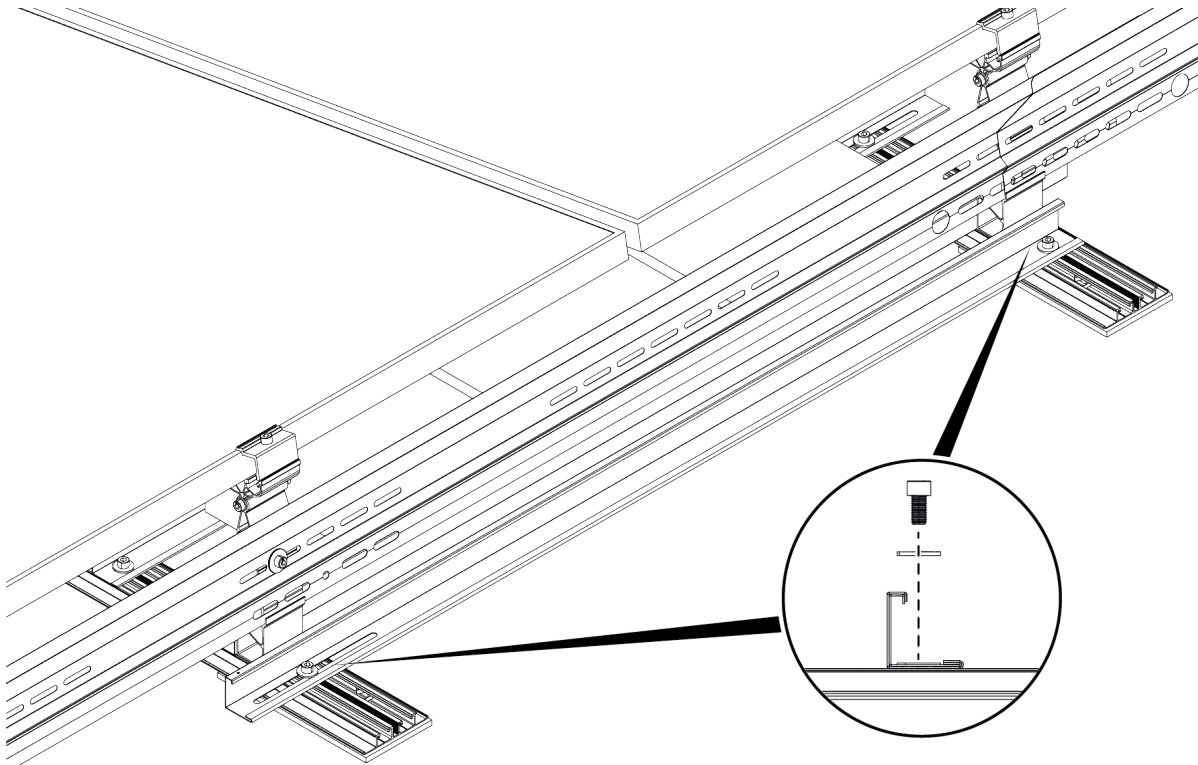

- Attach an outer cross-member to the rear brackets between the module rows.
- Make sure that the distance of 2 cm between the modules is maintained.
- Screw the cross-member with Allen screw (AB8x18S) and washer to the base rail.

Secure ballast with cross-members

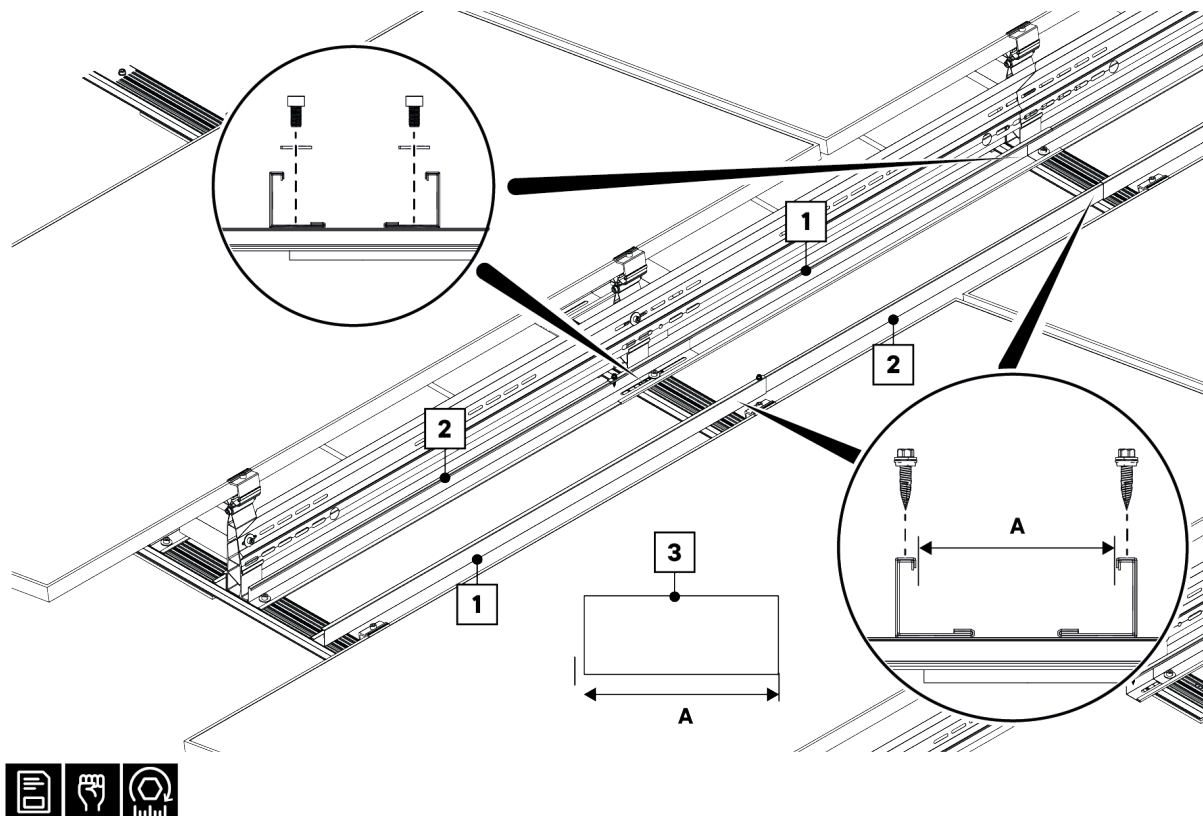

- ▶ Use the outer part (1) and inner part (2) of the cross struts alternately and push them into each other.
- ▶ Position the cross-members flush with the base rail at the outer edge of the module field.
- ▶ Screw the cross-members with an Allen screw (AB8x18S) and washer to the base rail.
- ▶ Tighten the screws to 10 Nm with a torque wrench.
- ▶ Screw the cross-members at each point of overlap with oblong holes with a thin sheet metal screw.

i If the ballast rails overlap at a point where there is no base rail, the ballast rails are only connected to the sheet metal screws.

MOUNT THE DOUBLE ROOF ANCHOR CONNECTION (OPTIONAL)

i The roof anchors are not included in the scope of delivery and must be provided by the customer. The roof anchor must be fitted with an **M10** or **M12 threaded rod** or a screw with the same diameter.

CONNECT SYSTEM WITH ROOF ANCHOR

i The double roof anchor is connected to the roof anchor with the U-rail via two base rails.



i The nut (1) and washer (2) are not included in the scope of delivery and must be provided by the customer.

- Attach the washer (4) and bracket (3) to the on-site threaded rod of the anchor.
- Attach with a washer (2) and nut (1) and then tighten to a torque of 15 Nm.

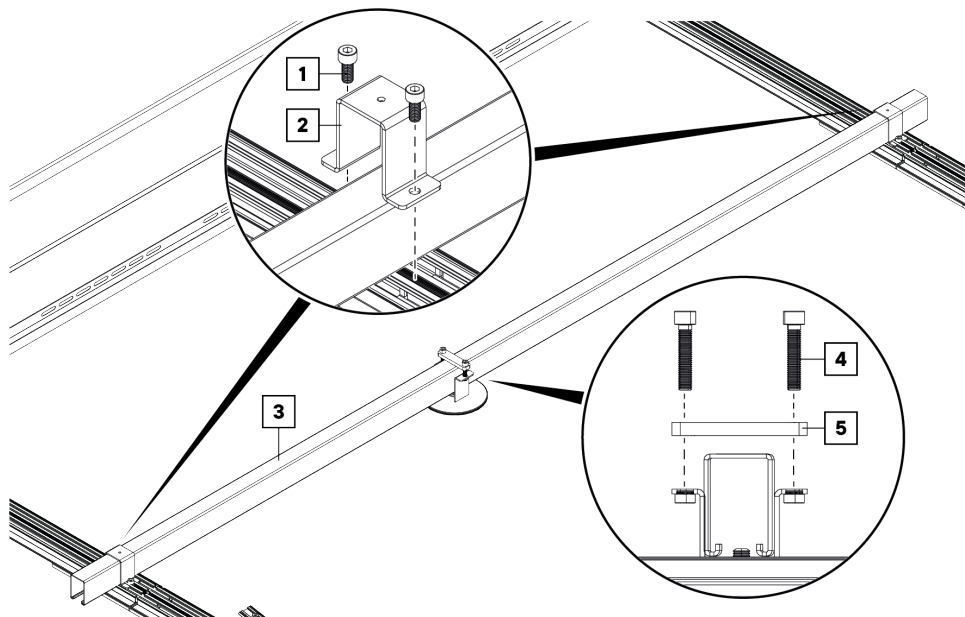
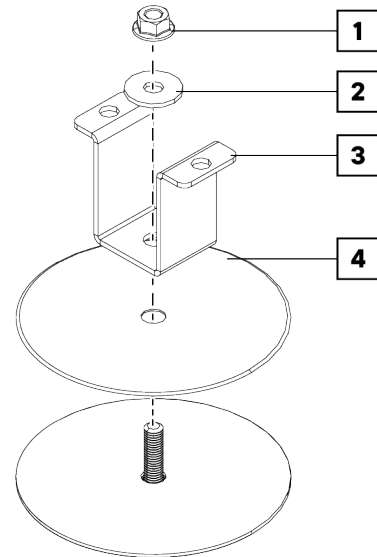

- Position the U-rail (3) precisely so that it can be securely fastened both with the bracket on the roof anchor and with two base rails.
- Tighten the U-rail (3) to the base rails with one bracket (2) and two screws (1) in the screw channel with a torque of 15 Nm or 11 ft-lb.
- Then attach the U-rail to the roof anchor using a plate (5) and two screws (4).

INSTALL SINGLE ROOF ANCHOR CONNECTION (OPTIONAL)

i The roof anchors are not included in the scope of delivery and must be provided by the customer. The roof anchor must be fitted with an **M10** or **M12 threaded rod** or a screw with the same diameter.

CONNECT SYSTEM WITH SINGLE ROOF ANCHOR

i The single roof anchor is intended for attachment to base rails. The use of the single roof anchor is particularly recommended for short base rails.



i The nut (1) is not included in the scope of delivery and must be provided by the customer.

- Attach the washer (4), bracket (3) and spacer (2) to the on-site threaded rod of the anchor.
- Make sure that the tab of the spacer (2) faces outwards.
- Fit the nut (1) - **2 to 3 threads, do not tighten.**

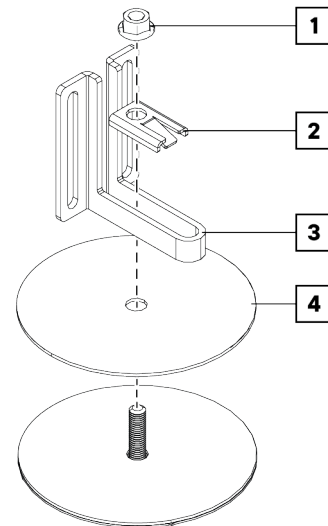

- To attach to the base rails, fit a sliding nut (5) in each channel next to the screw channel.
- Loosely fasten the bracket (4) to the bracket using two combination screws (2) and nuts (1).
- Fasten the bracket (4) to the base rail using the combination screws (3).
- Tighten all combination screws to a torque of 15 Nm or 11 lb-ft.
- Then tighten the nut (6) to a torque of 15 Nm or 11 lb-ft.

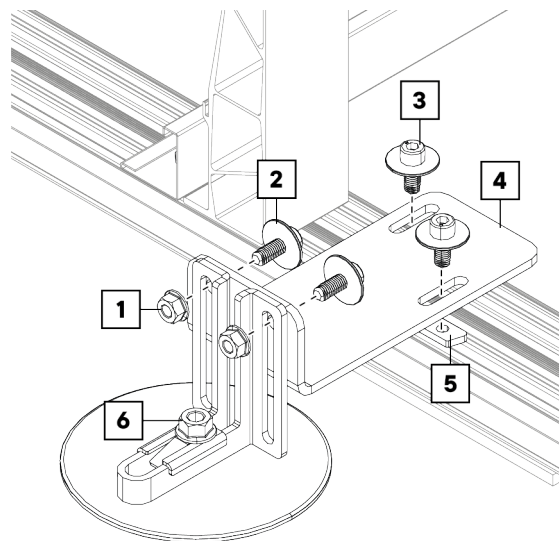

SN2 CABLE MANAGEMENT

MOUNT THE CLP-U CABLE CLIP TO THE BASE RAIL



- Insert the cable clip (1) into the base rail from above.
- Rotate the cable clip by 90°.

i Attention:

Make sure that the cable clip is fully engaged in the rail channel.

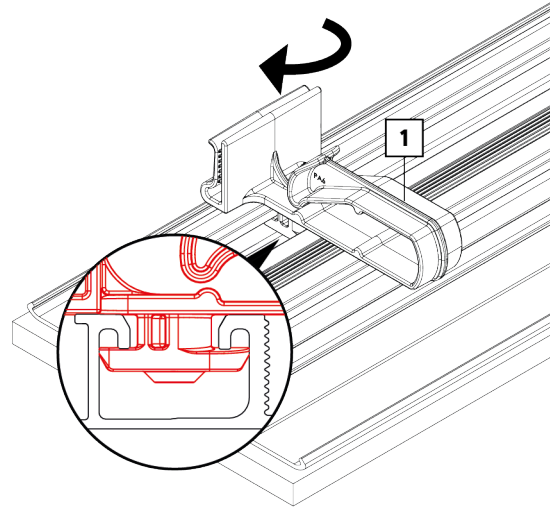

- The CLP-U (1) is suitable for:
 - A** - Solar connectors (e.g. MC4)
 - B** - Solar wire

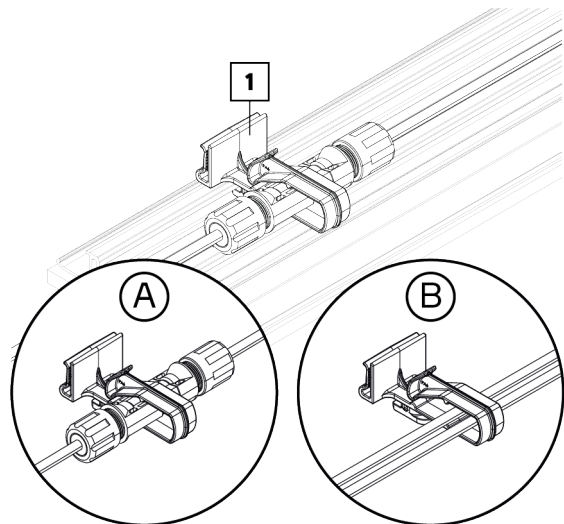

CABLE CLIP CLP-U FOR MODULES

i The **CLP-U cable clip** is suitable for module frames with a sheet thickness of **1.5 - 3 mm**.

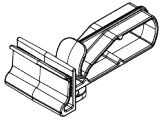

CLP-U
Cable clip universal

ASSEMBLY



- Insert the CLP-U (1) into the module frame.
- The CLP-U is suitable for:
 - A - Solar connectors (e.g. MC4)
 - B - Solar wire

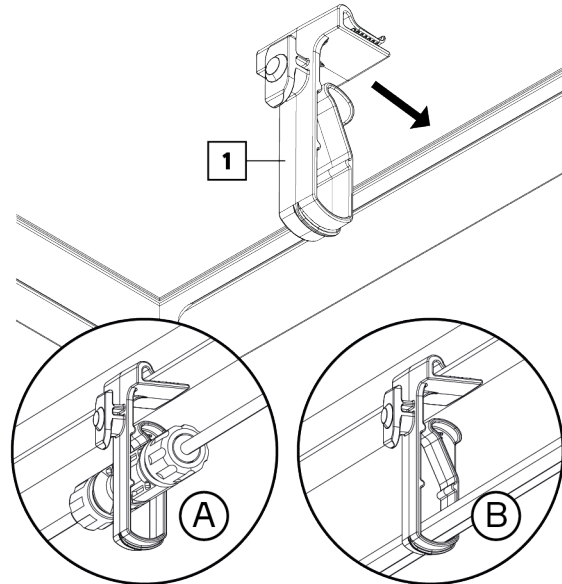

CABLE CLIP CLP-M FOR MODULES

i The **CLP-M cable clip** is suitable for module frames with a sheet thickness of **1 - 3 mm**.



CLP-M
Cable tie clip for module frames with a thickness of 1 - 3 mm

ASSEMBLY



- Insert the CLP-M (1) into the module frame.
- The CLP-M is suitable for:
 - Solar plug (e.g. MC4)
 - Solar cable
- Then tighten the cable tie (2).

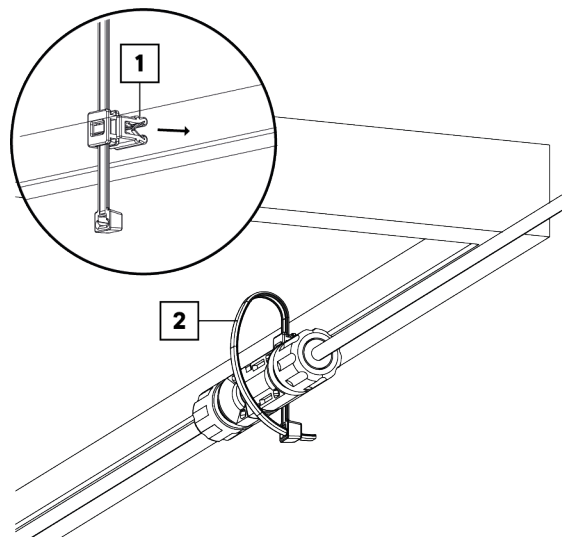

FITTING THE SNCP125 CONNECTING PLATE FOR BASE RAILS

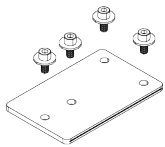

SNCP125
Connecting plate BR125x80



- ▶ Position the base rail (2) rotated by 90° (front side) as shown in the illustration.
- ▶ Place the connecting plate (1) in position and then screw tight with 4 pcs. M8x18 screws (3).
- ▶ The tightening torque of the screws (3) is 15 Nm or 11 lb-ft.

i 4 pcs. **M8x18 mm** screws (1) are used to fasten the connecting plate. **Important** - The screws for the cable tray must be organized by the customer.

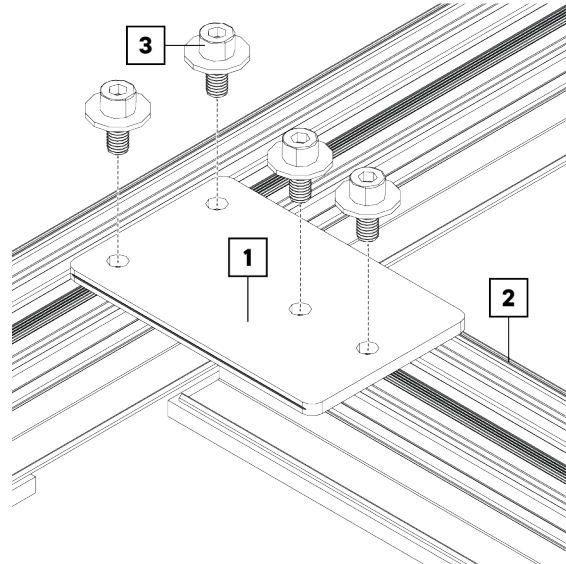

INSTALLING THE CABLE TRAY

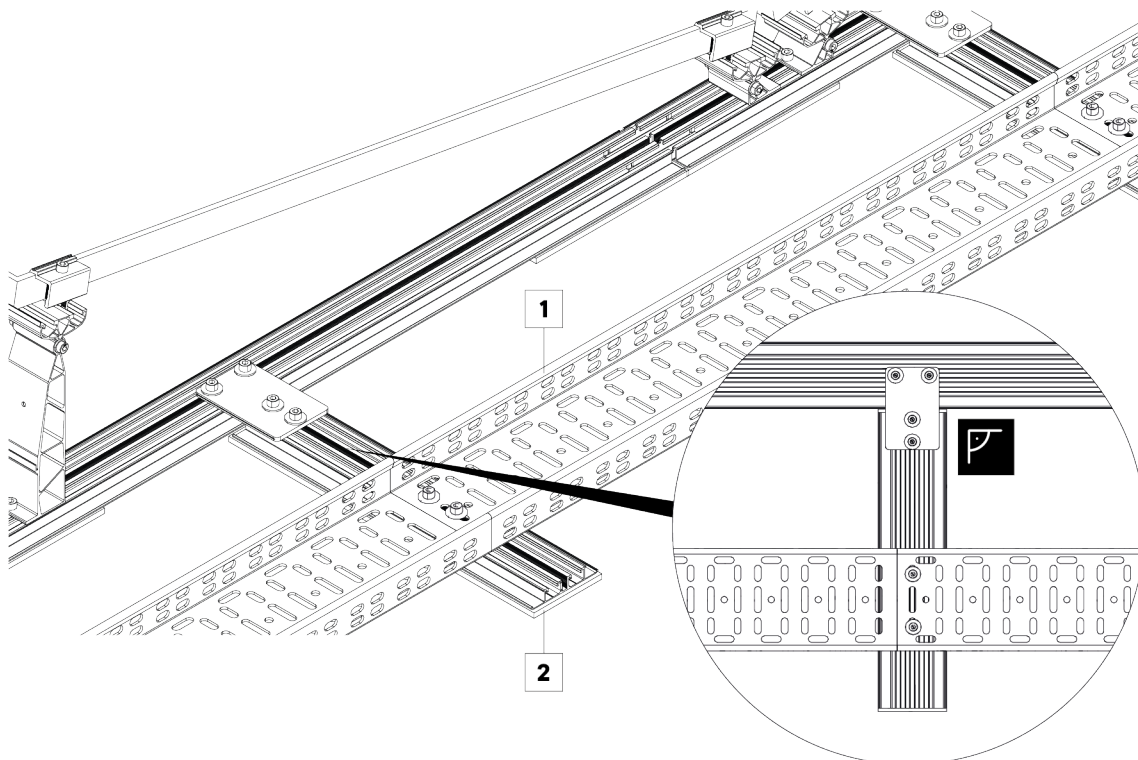

i The cable tray (1) and the fastening material must be organized by the customer, which means that the ballasting must also be planned by the customer; **no** ballasting specifications are provided in the planning documents from AERCOMPACT Europe GmbH. The base rail (2) is included in the scope of delivery and is available in lengths of **450 mm** or **900 mm**.

FITTING THE SNCLP-R CABLE CLIP

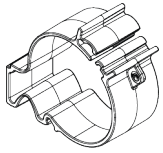

SNCLP-R
Cable clip SN2 rail

CLICK IN SNCLP-R



- ▶ Click in the SNCLP-R (1).

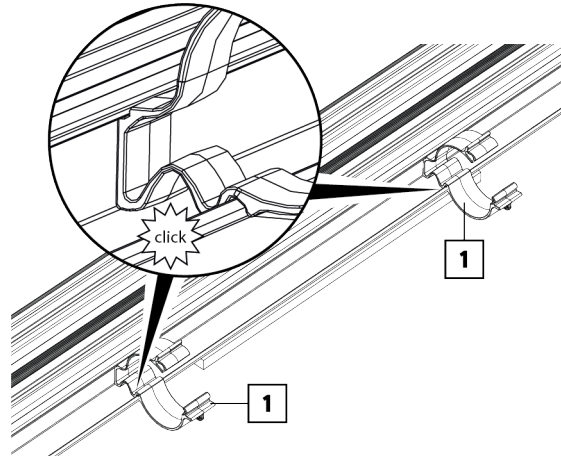

ATTACH CABLE PIPE



- ▶ Place the cable pipe (1) on the cable clips (2).
- ▶ Then engage the cable clip lock (2).

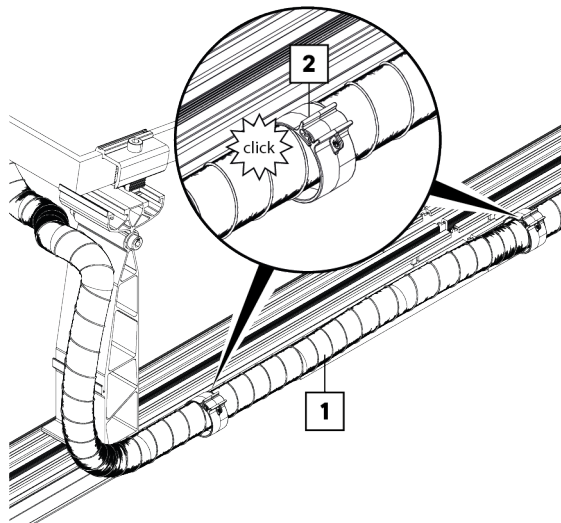

POTENTIAL EQUALIZATION

INSERT WIRE CLAMP



- Insert the wire clamp (1) into the base rail (2)

i Depending on the requirements, either the right or left channel of the base rail can be used to insert the wire clamp (1).

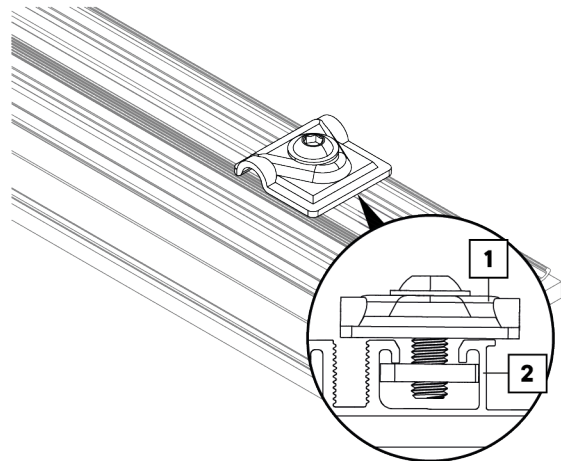

POTENTIAL EQUALIZATION

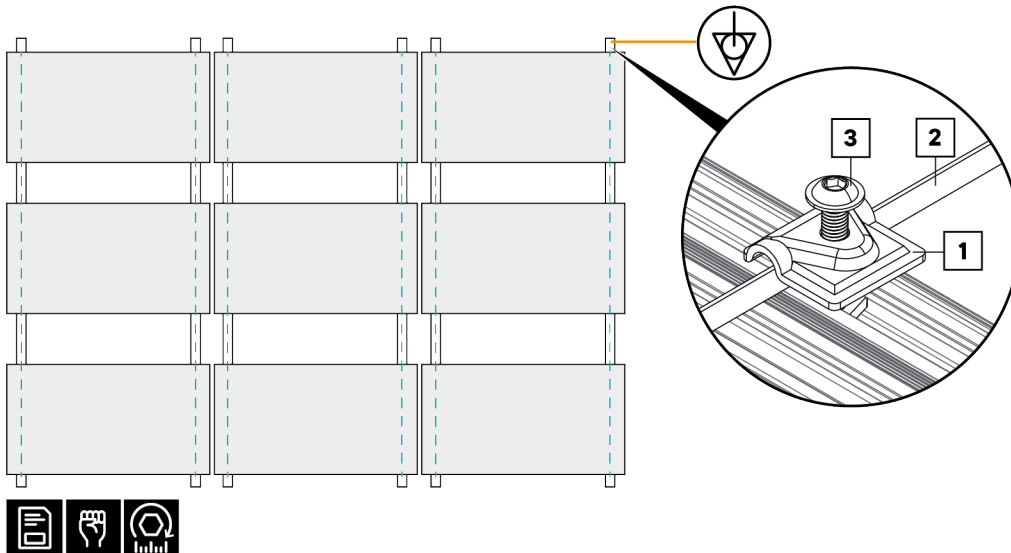

- Insert the ground wire (2).
- Tighten the screw (3) of the wire clamp (1) with a torque of 10 Nm or 7.3 lb-ft.

i The ground wire (1) must be organized **on site**.

POTENTIAL EQUALIZATION CONNECTED RAIL

i To ensure the connection between the module rows, it is necessary to establish a connection to the rail joints located outside the modules (1). It is **not necessary** to make a connection for rail joints that are located under a module (2).

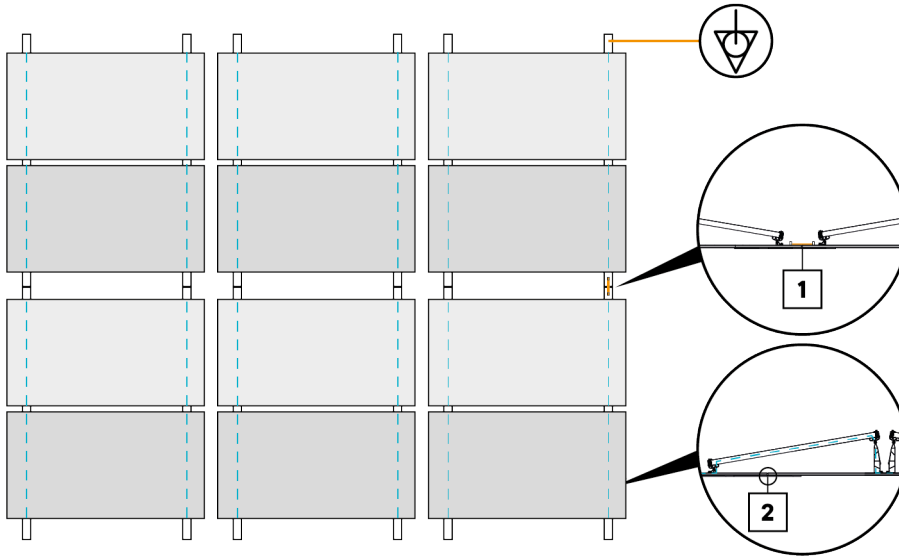

- Rail joints (1) that are not located under a module must be connected using two wire clamps and an grounding wire.
- If the rail joints (2) are located under a module, **no further action** is required.

EQUIPOTENTIAL BONDING DURING MAINTENANCE WORK

i Caution!

To ensure that the connection between the remaining modules and the potential equalization is guaranteed, additional earthing terminals and earthing wire must be attached when a module is removed.

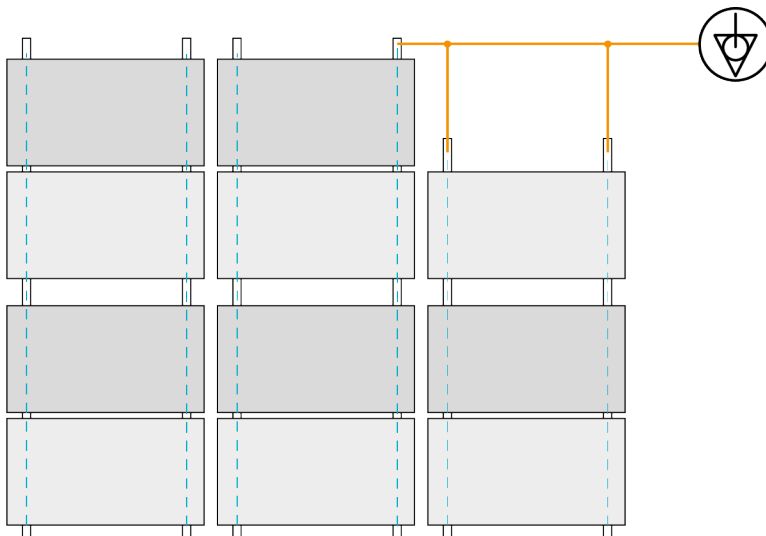

MAINTENANCE, DISASSEMBLY AND DISPOSAL

MAINTENANCE

To prevent personal injury and damage to property, the system must be checked regularly by qualified personnel and annual maintenance is required.

- Check all system components for damage. In the event of damage, replace the affected component immediately.
- Check all screw connections. Tighten loose screw connections, observing the tightening torque specified in the installation instructions.
- Checking all components for damage caused by the weather, animals, dirt, deposits, build-up, vegetation, roof penetrations, seals, stability and corrosion. In the event of damage, clean, repair or replace the affected component.

DISASSEMBLY

DISMANTLING THE CLAMPS (EXAMPLE)



i To disassemble the system, carry out the assembly steps in reverse order.

- Unscrew the screw (1) on the clamp.
- When reusing the clamp, ensure that the O-ring (2) is not lost.
- i** If the components are reused, it must be noted that these are wearing parts. Therefore, the AEROCOMPACT Europe GmbH cannot assume any responsibility for checking the degree of wear. For this reason, any liability or warranty of AEROCOMPACT Europe GmbH in case of reuse is excluded and reuse is at the installer's own responsibility.

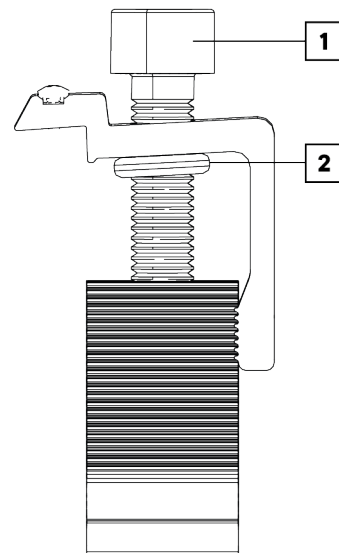

DISPOSAL

Unless a take-back or disposal agreement has been made, disassembled components should be recycled:

- Give metals and plastic elements for recycling.
- Dispose of remaining components sorted according to material composition.

i Incorrect disposal may result in hazards to the environment. In case of doubt, obtain information on environmentally sound disposal from the local municipal authority or from specialized disposal companies.

APPENDIX

DECLARATION OF PERFORMANCE



Manufacturer: **AEROCOMPACT Europe GmbH**
Designation: **CompactFLAT SN2 PLUS and CompactFLAT SN2 Q PLUS rail system for flat roofs**
Identification code: **SN2 PLUS, SN2 Q PLUS**
Applied standard: **EN 1090-1**
Certification body: **2397**



[To the declaration of performance](#)

REVISION HISTORY

Version	Chapter	Modification
v3.2	"SN2 Mounting gauge" on page 19	New chapter added
v3.3	"SN2 Cable management" on page 35	New chapter added

Europe / APAC

AEROCOMPACT® Europe GmbH
Gewerbstraße 14
6822 Satteins
Austria
phone: +43 5524 22 566
e-mail: office@aerocompact.com

USA / Canada

AEROCOMPACT® Inc.
901A Matthews Mint Hill Road
Matthews, NC 28105
USA
phone: +1 800 578 0474
e-mail: office.us@aerocompact.com

India

AEROCOMPACT® India Private Ltd.
Hub and Oak
C-360, Defence Colony
New Delhi, 110024
phone: +91 888 26 32 902
e-mail: office.in@aerocompact.com

