

---

Assembly Instruction

## COMPACTMETAL™

Version : 3.4

Language : English

Important! Read carefully before installation!

---



## **Legal Notice**

Subject to change due to technical modifications! These assembly instructions correspond to the technical status of the delivered product and not to the current development status at the manufacturer. If pages or parts of the assembly instructions are missing, please contact the manufacturer's address given below. The original language of these assembly instructions is German. Any assembly instructions in another language are a translation of the assembly instructions in German. Therefore, in case of doubt or contradiction, the authentic German version shall prevail. The installation instructions are protected by copyright. The installation instructions may not be copied, reproduced, microfilmed, translated or converted for storage and processing in computer systems, either in part or in full, without the written permission of AEROCOMPACT Europe GmbH

Copyright by AEROCOMPACT Europe GmbH

## **Manufacturer**

AEROCOMPACT Europe GmbH  
Gewerbestrasse 14  
6822 Satteins, Austria

[office@aerocompact.com](mailto:office@aerocompact.com)  
[www.aerocompact.com](http://www.aerocompact.com)

## **Creation date**

10/2024

# TOC

---

<b>General</b> .....	<b>4</b>
Applicable documents .....	4
Limitation of liability .....	4
Explanation of symbols .....	4
<b>Safety</b> .....	<b>5</b>
Appropriate use .....	5
Personnel requirements .....	5
Working safely .....	5
Breakthrough protection .....	6
Personal protective equipment (PPE) .....	6
<b>System Overview</b> .....	<b>7</b>
Basic components TM .....	7
System accessories .....	8
Mounting rails and accessories .....	8
Module accessories .....	8
Potential equalization .....	8
<b>Assembly</b> .....	<b>9</b>
Assembly preparation .....	9
Required tools for assembly .....	9
Measure area .....	10
Mount seam clamps .....	11
TMD - Double seam clamp .....	11
TMM - Angle seam clamp .....	12
TMR - Round seam clamp .....	13
TMK1508   TMK2008 - Sheet metal seam clamps .....	14
TMRD08 - Sheet metal seam clamp .....	15
Mount EL05 height adapter (optional) .....	16
Mount modules .....	17
Assemble first module row .....	17
Mount mounting rail (optional) .....	19
Mounting modules on mounting rail X40/X50 .....	21
Cable management .....	23
MLPE for mounting Mounting rail (optional) .....	24
Potential equalization .....	25
<b>Maintenance, disassembly and disposal</b> .....	<b>26</b>
Maintenance .....	26
Disassembly .....	26
Disposal .....	26
<b>Appendix</b> .....	<b>27</b>
Declaration of performance .....	27
Revision history .....	27

# GENERAL

These assembly instructions describe the assembly procedure and must be strictly adhered to. Read these installation instructions carefully before starting installation. The basic prerequisite for safe working is compliance with all the safety and handling instructions in these installation instructions. In addition, the local accident prevention regulations and general safety regulations for the area of application of the product apply. Illustrations in these instructions are for basic understanding and may differ from the actual design.

## APPLICABLE DOCUMENTS

In addition to this manual, you have received an AEROTOOL project report, planning documents and drawings. Always comply with the instructions and notes contained therein.

## LIMITATION OF LIABILITY

All information and instructions in these assembly instructions have been compiled taking into account the applicable standards and regulations, the state of the art and our many years of knowledge and experience. Liability provisions are stated in our **terms** and can be accessed at [www.aerocompact.com/downloads](http://www.aerocompact.com/downloads).

## EXPLANATION OF SYMBOLS

### SYMBOLS FOR INSTRUCTIONS



Prerequisites for action instruction



Results of action steps



Step by step action instruction



This note provides useful information for smooth installation

### SYMBOLS IN ILLUSTRATIONS - ACTIVITIES



Optional component, optional mounting variation



Activity by hand



Check AEROTOOL project report or planning documents



Visual inspection



Observe right angle

### SYMBOLS IN ILLUSTRATIONS - TOOLS



Measuring tape, measure



Pencil, mark



Chalk line



Scissors, tin snips, cut to size



Cordless screwdriver, screwdriver



Use a torque wrench, Observe torque



Use Allen key

# SAFETY

The following list serves as an indication of the most common safety risks that can occur when installing these products. There is no liability for the completeness of the risks presented. A specific check of the necessary safety measures must be carried out by an authorized specialist company before installation.

## APPROPRIATE USE

The TM system is designed exclusively for mounting PV modules on metal roofs with standing seams. Suitable clamps are available for the various standing seams. Proper use also includes correct installation in accordance with these installation instructions. Approval from the module manufacturer is required for the use of PV modules with the TM system. AEROCOMPACT accepts no liability for loss of performance or damage of any kind to the PV modules. Any other use of the TM system is considered improper use.

### NOTE ON THE PROCESSING OF THIN SHEET METAL SCREWS

**i** The attachment of thin sheet metal screws with impulse or impact screwdrivers is not permitted. The high speeds can cause damage to the screw bodies, the flashing and the sealing. Thin sheet metal screws may **only** be used **once**, as their performance is not guaranteed if they are reused.

**☒** Apply pressure to the thin sheet metal screw and screw in at low speed (< 500 rpm).

**☒** Then reduce the pressure and screw in the thin sheet screw at a higher speed.

## PERSONNEL REQUIREMENTS

Installation may only be carried out by a specialist company and must be carried out strictly in accordance with the installation instructions, the project report and the planning documents. A specialist company is a company that is familiar with the installation and maintenance of photovoltaic systems as part of its normal business operations. National and local building regulations, standards and environmental protection must be complied with. Under no circumstances may the assembly personnel be under the influence of medication, alcohol, drugs or in any other condition that impairs consciousness (e.g. overtiredness). Trainee personnel may only carry out work under the instruction and supervision of specialist personnel who are authorized to train personnel.

## WORKING SAFELY

The contractual partner must ensure that the necessary safety measures and the relevant labor law and occupational safety regulations are observed when installing products from AEROCOMPACT Europe GmbH. Information from AEROCOMPACT Europe GmbH on the need to comply with security measures is provided without guarantee and without any claim to completeness and serves only to support the contractual partner. The contractual partner is obliged to inform himself about all relevant regulations concerning working safety and to comply with them. AEROCOMPACT Europe GmbH expressly assumes no responsibility and consequently no liability. Areas below the roof on which work is being carried out must be protected from falling objects. Where this is not possible, the affected areas must be closed to the public and unauthorized personnel. If the weather is unsuitable, work on the roof must not be continued for longer than necessary or must not be started at all. Never carry out installation work in strong winds. Strong winds exert particular enormous forces on the large-area PV modules. There is a risk of a module being torn off the roof and people being injured. Never work in wet conditions or at temperatures below freezing. Depending on the roof pitch, there is a risk of slipping. Only use suitable, intact and tested ladders. Set up and secure ladders according to specifications. Separate rules apply to mechanical climbing aids (elevators, cherry pickers, etc.). Never use the PV mounting system as a climbing support. Keep sufficient distance from overhead power lines. Equipotential bonding between the individual system components must be carried out in accordance with the respective country-specific regulations. When cutting materials to size, make sure there are no burrs, especially on edges and corners where there is a risk of injury.

# BREAKTHROUGH PROTECTION

Roof windows, skylights, large ventilation flaps, etc. generally cannot withstand the weight or impact of a person. Such objects must be secured in a similar way to the roof edge. Corrugated fiber-cement roofs can be at risk of breakthrough over the entire surface. Define routes and secure them with load distribution measures. Always use load distribution aids on roof coverings or roof structures (e.g. thin sheet metal, corrugated fiber cement) with insufficient load-bearing capacity.

# PERSONAL PROTECTIVE EQUIPMENT (PPE)

Personal protective equipment is used to protect people from health and safety hazards at work. Personnel must wear personal protective equipment during installation. Personal protective equipment is explained below:



**Wear safety goggles when drilling and sawing**



**Wear cut-resistant work gloves during assembly**



**Wear safety shoes**



**Use fall protection**



**Helmets must be worn by all persons working on the construction site**



**Wear hearing protection**

# SYSTEM OVERVIEW

## BASIC COMPONENTS TM

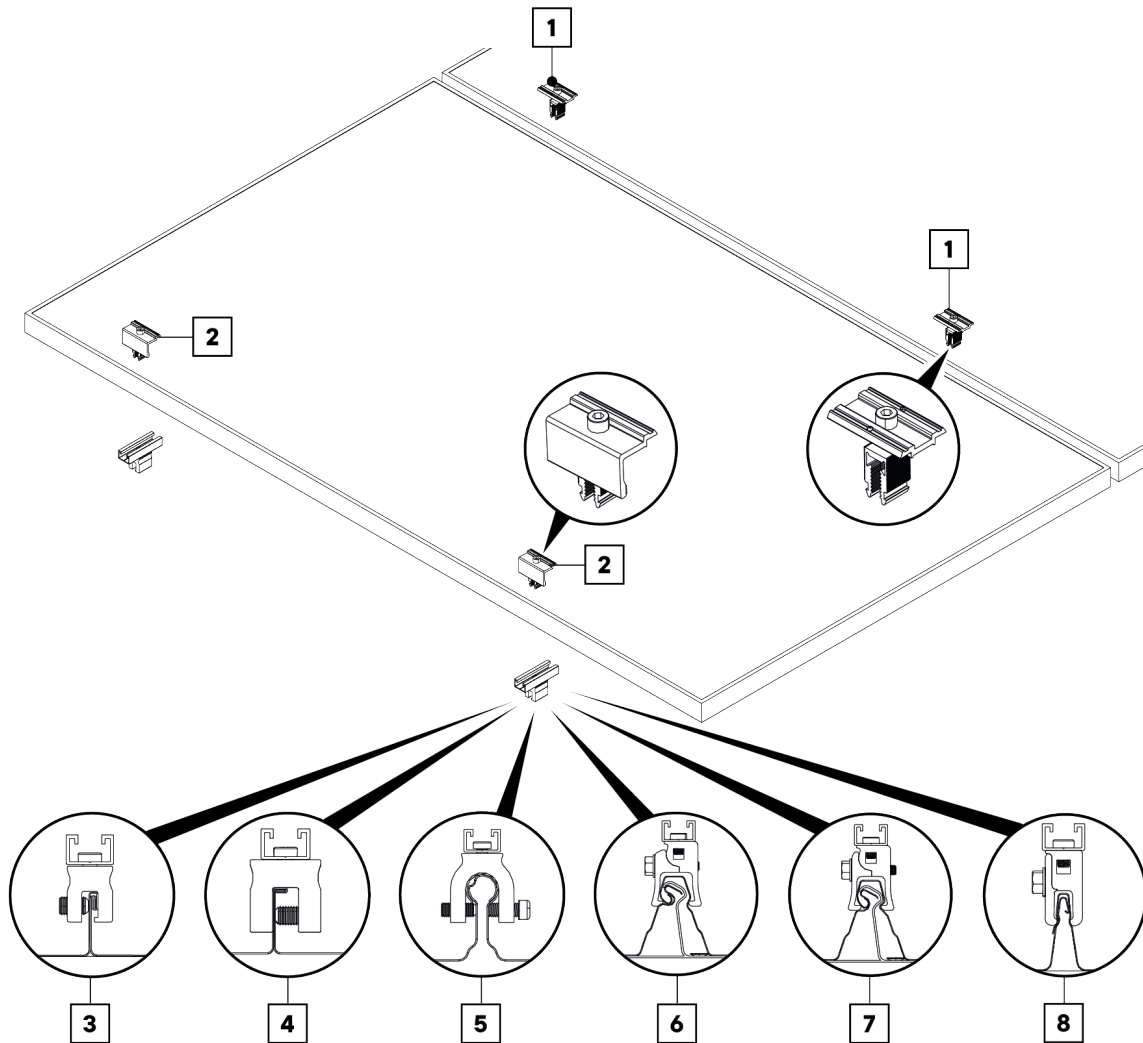

**1 CLM10**  
Middle clamp Click 30 - 46 mm

**3 TMDS08**  
Double-seam clamp with short rail

**5 TMR08**  
Rounded-seam clamp with short rail

**7 TMK1508**  
Sliding fold seam clamp medium

**2 CLE10**  
End clamp Click 30-46

**4 TMM08**  
Single-seam clamp with short rail

**6 TMK2008**  
Sliding fold seam clamp large

**8 TMRD08**  
Sliding fold seam clamp small

## SYSTEM ACCESSORIES

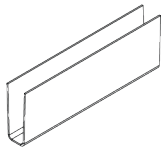

**DSA10**  
Stainless steel saddle seam roof 55 mm  
(for copper roofing)

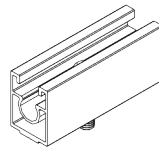

**EL05**  
Height adapter 33 mm

## MOUNTING RAILS AND ACCESSORIES



**X40-XXXX**  
Mounting rail X40 1980 mm 3300 mm 3550  
mm 4400 mm 4750 mm 5500 mm 5850  
mm

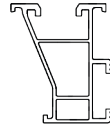

**X50-XXXX**  
Mounting rail X50 1980 mm 3300 mm 3550  
mm 4400 mm 4750 mm 5500 mm 5850  
mm

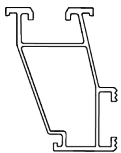

**X60-XXXX**  
Mounting rail X60 1980 mm 3550 mm 4750  
mm 5850 mm

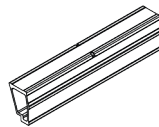

**XPCN60**  
Rail connector X60



**XPCN-XX**  
Rail connector X40, X50

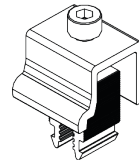

**XDL**  
Cross connector X40, X50, X60

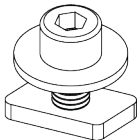

**SCR-MA**  
Bolting set module accessories

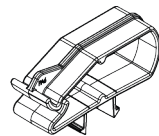

**CLP-R**  
Cable clip rail

## MODULE ACCESSORIES

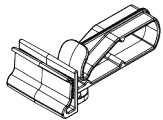

**CLP-U**  
Cable clip universal



**CLP-M**  
Cable tie clip for module frames with a  
thickness of 1 - 3 mm

## POTENTIAL EQUALIZATION

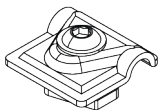

**WCL8-10**  
Wire clamp 8 - 10 mm



# ASSEMBLY

## ASSEMBLY PREPARATION

### Required tools for assembly

**i** Before starting the assembly, make sure that the assembly personnel are familiar with the proper use of the listed tools.



**Bit hexagon socket 6 mm**



**Bit hexagon socket 5 mm**



**Measuring tape**



**Bit TORX T40**



**Cordless screwdriver**



**Torque wrench 10 - 30 Nm with hexagon socket bit 6mm**



**Open-end wrench SW13**

## MEASURE AREA

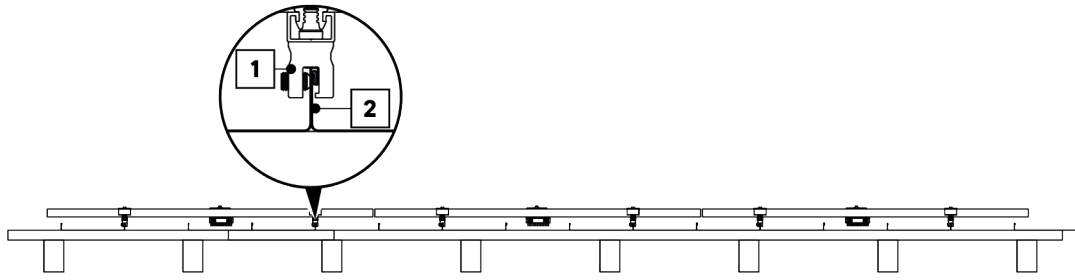

➤ The seam clamp (1) is mounted on the roof seam (2). The distance between the seam clamps depends on the width/length of the modules and the distance between the roof seams.

ⓘ The seam clamps must never be attached to the **sliding clamps** or in the **joint area** of the sheets.

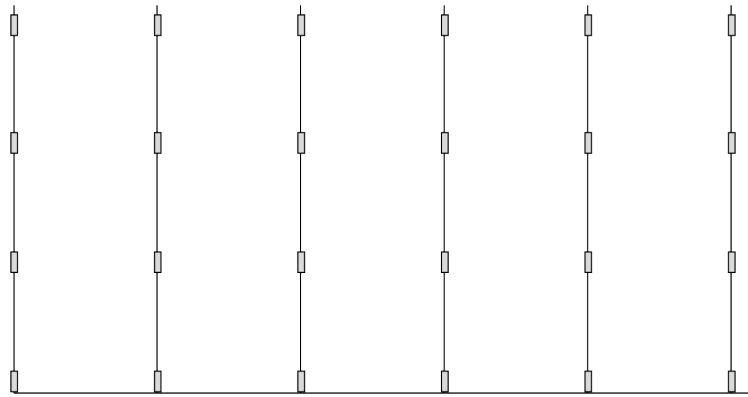

- Take over the dimensions of the module field from the planning documents.
- Determine module dimensions.
- Determine the position of the roof seams of the metal roof.

## MOUNT SEAM CLAMPS

### TMD - Double seam clamp



- Attach the double seam clamp to the roof seam.

❗ The clamps must never be attached to the **sliding** clamps or in the **joint area** of the sheets.

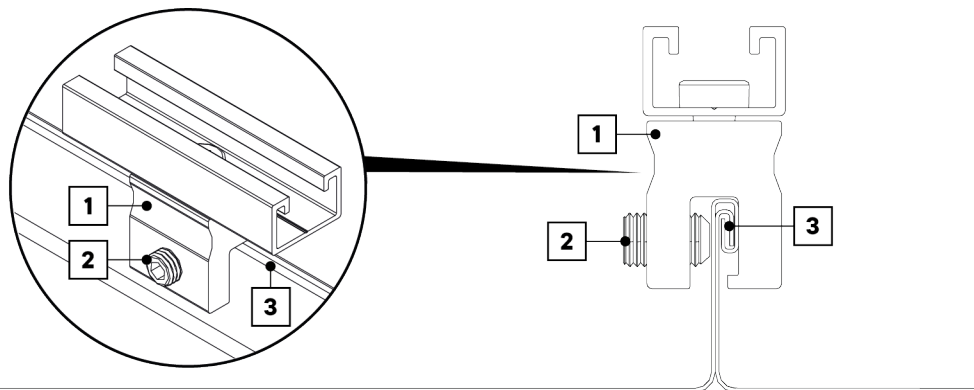
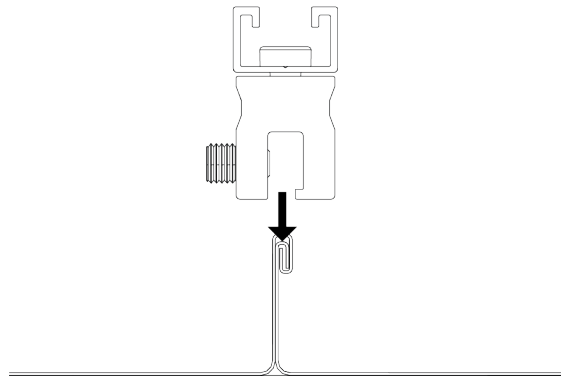

- Tighten the grub screw (2) with a torque of 18 Nm or 13.28 lb ft until the double seam clamp (1) is flush with the roof seam (3).
- If the sheet thickness exceeds **0.7 mm**, the grub screw (2) must be tightened with a torque of 20 Nm or 14 lb-ft.
- Place the other double seam clamps at the marked points on the sheet metal roof.

### ATTACH STAINLESS STEEL SADDLE



❗ The stainless steel saddle acts as galvanic insulation between the seam clamps and the sheet metal seam to prevent contact corrosion, especially on copper roofs.

- Install the stainless steel saddle flush on the roof seam.
- Attach the double seam clamp to the roof seam.
- Tighten the grub screw so that the double seam clamp is flush.
- Then tighten the grub screw to a torque of 20 Nm or 14.75 lb ft.

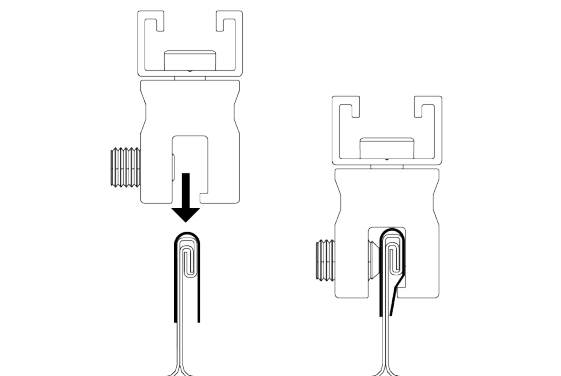

## TMM - Angle seam clamp



- Attach the angle seam clamp to the roof seam.

**i** The clamps must never be attached to the **sliding** clamps or in the **joint area** of the sheets.

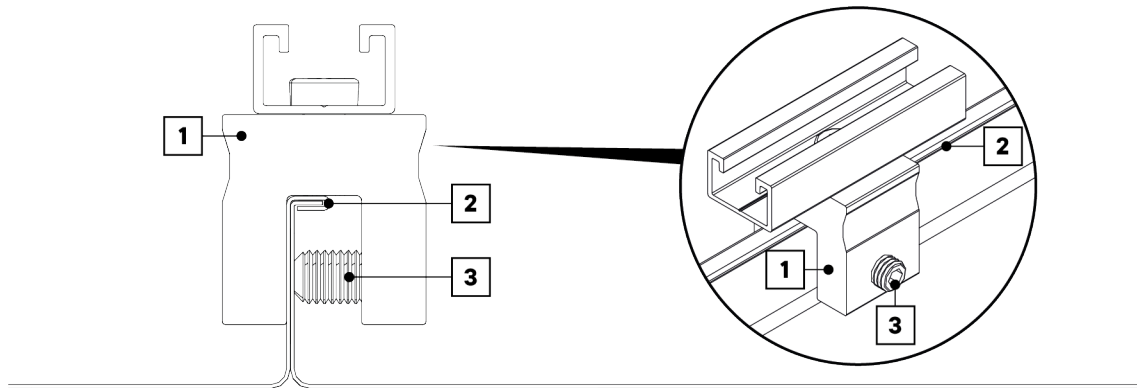
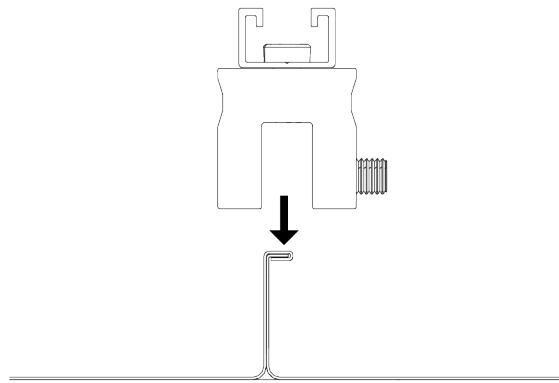

- Tighten the grub screw (2) with a torque of 18 Nm or 13.28 lb ft until the angled seam clamp (1) is flush with the roof seam (3).
- If the sheet thickness is more than **0.7 mm**, the grub screw (2) must be tightened to a torque of 20 Nm or 14 lb-ft.
- Place the other angle seam clamps at the marked points on the sheet metal roof.

## TMR - Round seam clamp



- Attach the round seam clamp to the roof seam.

**i** The clamps must never be attached to the **sliding** clamps or in the **joint area** of the sheets.

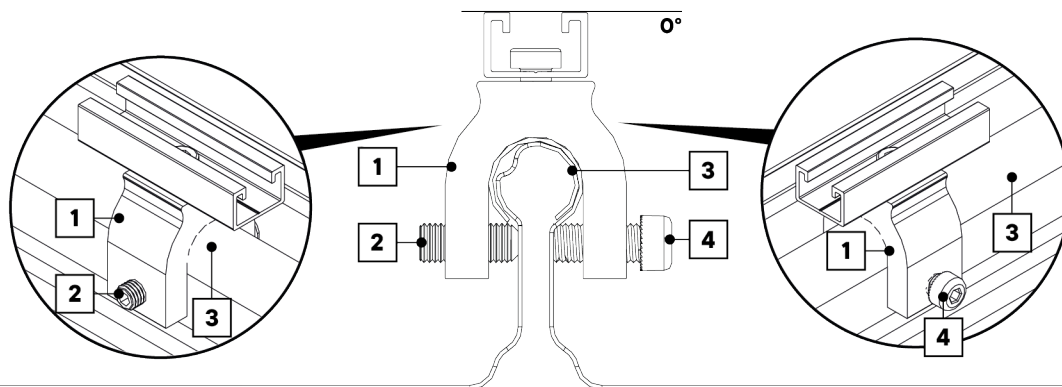
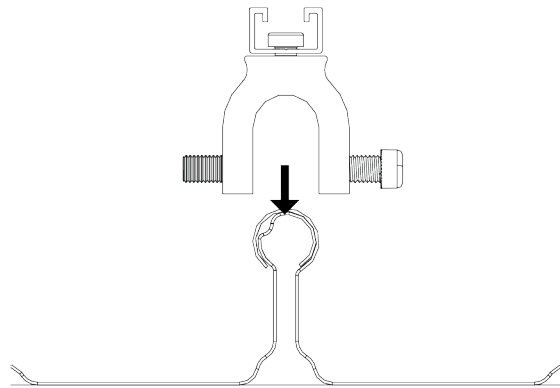

- Tighten the grub screw (2) and the Allen screw (4) evenly until the round seam clamp (1) just rests on the roof seam (3).
- Tighten both screw (2) and (4) with a torque of 18 Nm or 13.28 lb ft.
- If the sheet thickness exceeds **0.7 mm**, the grub screw (2) must be tightened with a torque of 20 Nm or 14 lb ft.
- Place the other round seam clamps at the marked points on the sheet metal roof.

## TMK1508 | TMK2008 - Sheet metal seam clamps



- ▶ Loosen screw (1).
- ▶ Insert the sheet metal seam clamp (2) at the sheet metal seam (3)

### **i Attention!**

The orientation of the clamp must be observed. The sheet metal seam clamp should be positioned so that the screw (1) points in the direction of the overlapping sheet metal (3).

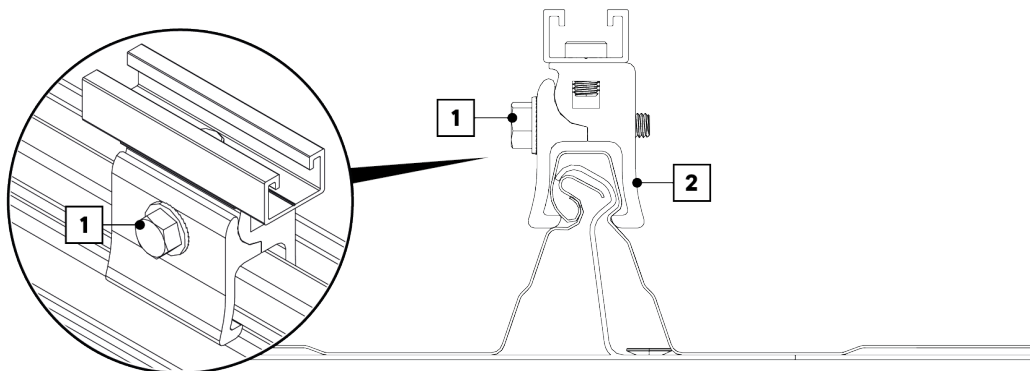
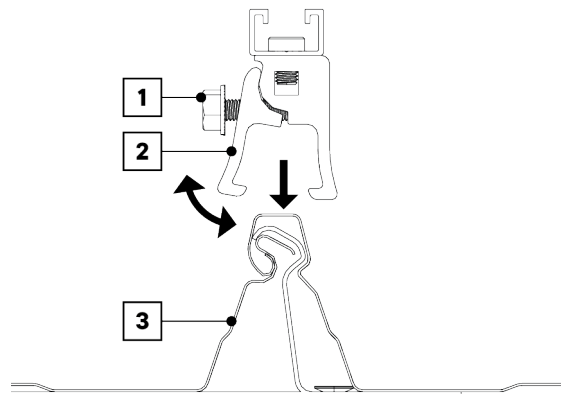

- ▶ Position the sheet metal folding clamp (2) according to the illustration and tighten the screw (1) with a torque of 18 Nm or 13.28 lb ft.
- ▶ If the sheet thickness exceeds **0.7 mm**, the grub screw (2) must be tightened with a torque of 20 Nm or 14 lb ft.
- ▶ Attach the other sheet metal seam clamps to the marked locations on the sheet metal roof.

## TMRD08 - Sheet metal seam clamp



- ▶ Loosen screw (1).
- ▶ Open the sheet metal seam clamp (2) and attach it to the sheet metal seam according to the illustration.

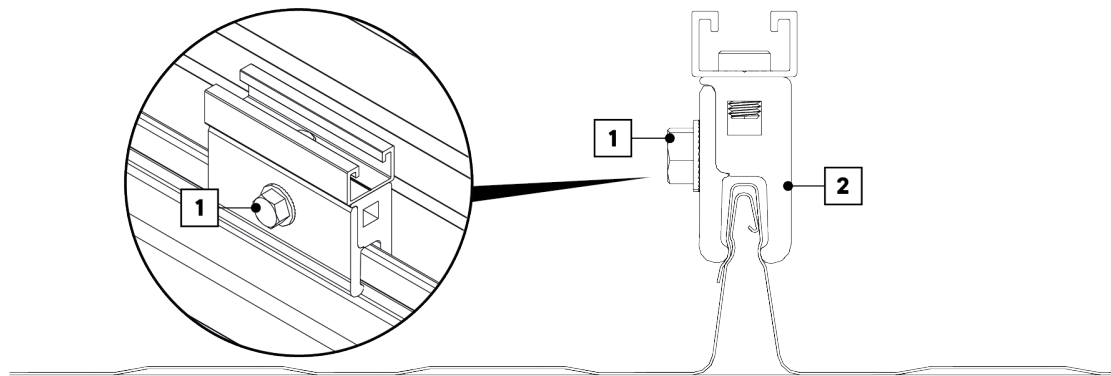
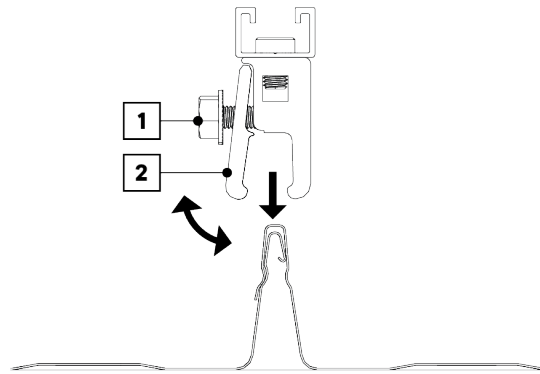

- ▶ Position the sheet metal folding clamp (2) according to the illustration and tighten the screw (1) with a torque of 18 Nm or 13.28 lb ft.
- ▶ If the sheet thickness is more than **0.7 mm**, the grub screw (2) must be tightened to a torque of 20 Nm or 14 lb-ft.
- ▶ Attach the other sheet metal seam clamps to the marked locations on the sheet metal roof.

## MOUNT EL05 HEIGHT ADAPTER (OPTIONAL)

**i** The **EL05** height adapter is mounted to create an extended distance between the roof surface and the modules.

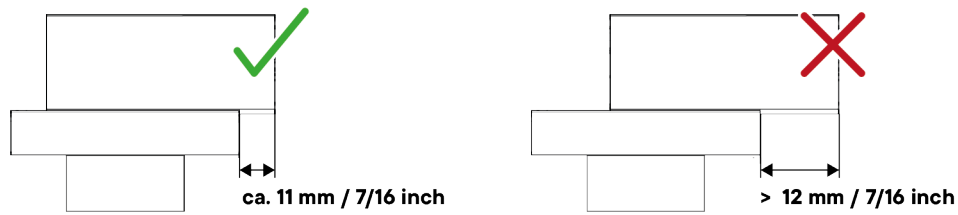

**i** The fastening screw of the short rail prevents the EL05 height adapter from being placed centrally.

- When mounting, make sure that the EL05 height adapter rests as fully as possible on the short rail.
- The maximum projection of the height adapter is 11 mm or 7/16 inch.

### MOUNTING HEIGHT ADAPTER

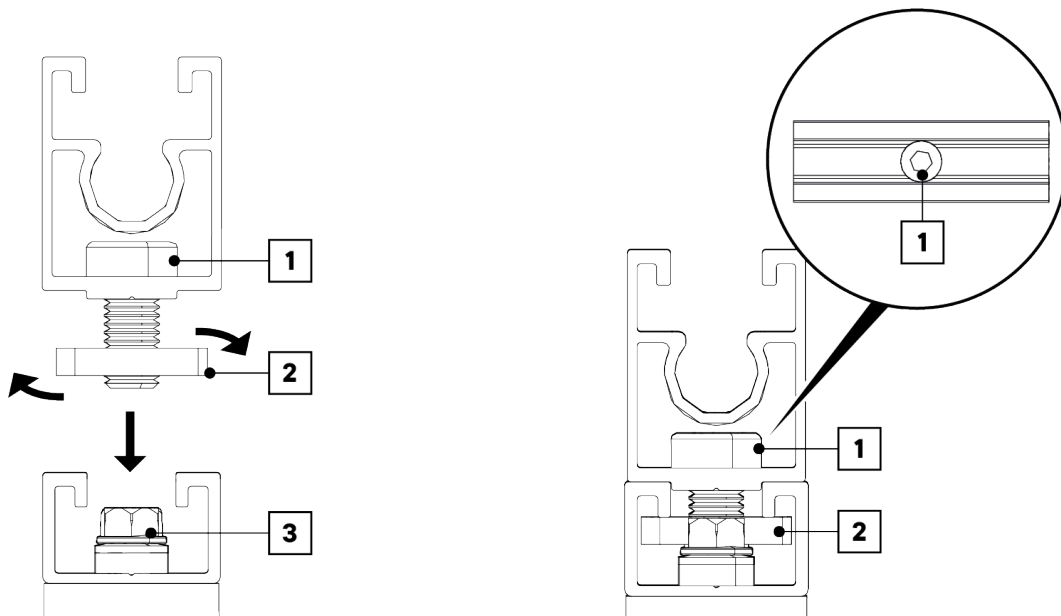

- Insert the hammerhead screw (2) in the mounting channel of the short rail.
- Make sure that the hammerhead screw is placed next to the fixing screw (3) (**ridge side**).
- Tighten the screw (1) of the height adapter with a torque of 15 Nm or 11 ft lbs.



## MOUNT MODULES

**i** When mounting the modules, make sure that the module clamps are mounted as centrally as possible on the short rail / on the height adapter. Refer to the planning documents for the exact positions of the module terminals.

### RECOMMENDATION FOR WIRING THE MODULES



**i** **Installation tip:**

Before starting the module installation, install two CLP-U per module as shown in the illustration to ensure better accessibility for the subsequent cabling.

**➤** If necessary, slide the CLP-U cable clips out of the clamping area.

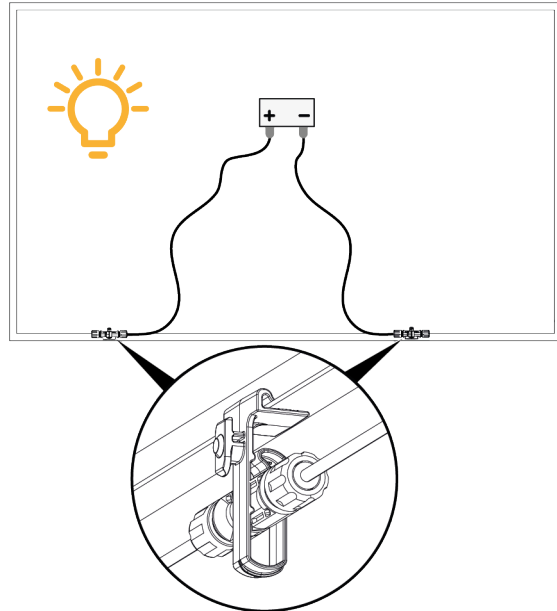

## Assemble first module row

**i** Do not step on the modules when mounting them.

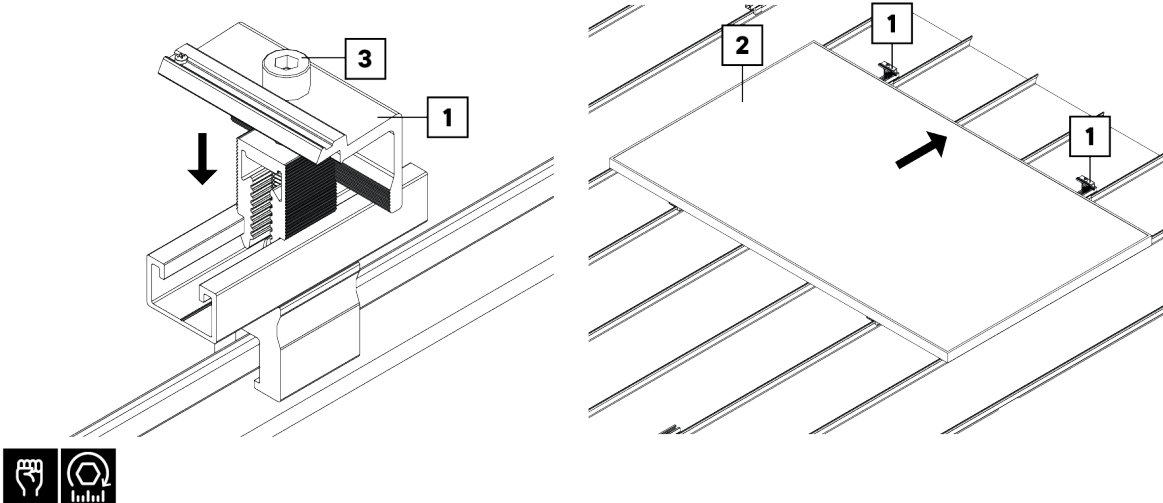

- Center the end clamps (1) on the outermost row of sheet metal seam clamps.
- Place the first module (2).
- Tighten the screws of the end clamps (3) with a torque of 15 Nm or 11 ft lbs.

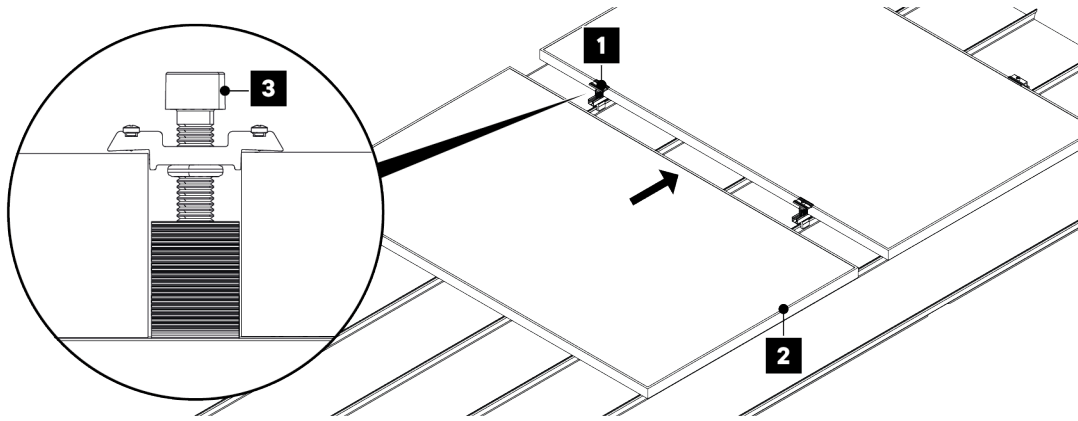

- After the first module, attach middle clamps (1) to the short rails/height adapters.
- Place the second module (2) flush against the middle clamps.
- Tighten the screws (3) on the middle clamps to 15 Nm or 11 ft lbs.

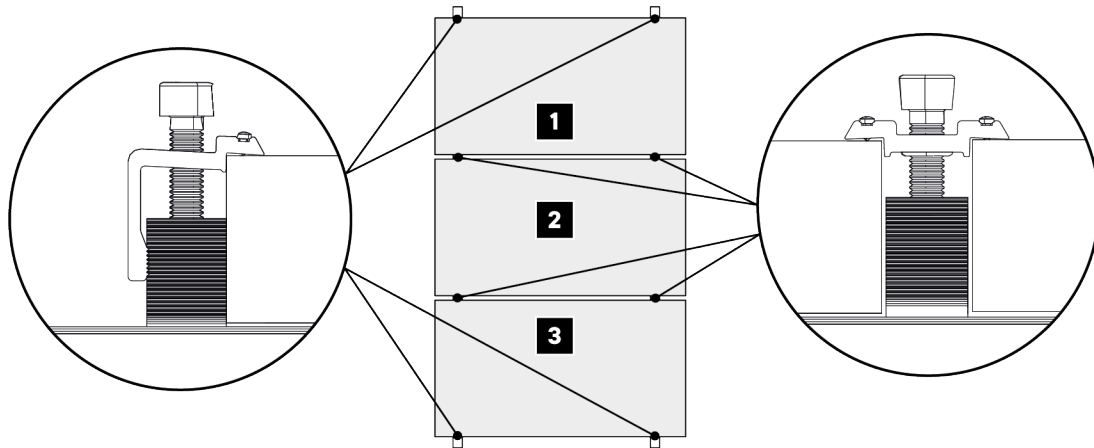

- Lay the modules row by row.
- Tighten the screws on the terminals to a torque of 15 Nm or 11 ft lbs.

#### REPOSITION / REPLACE CLAMPS

- Dismantle the mounted clamp: Unscrew the screw on the clamp completely.
- Depending on the installation situation, press the clamp together at the side and pull it out or pull it out of the rail at the side.

## MOUNT MOUNTING RAIL (OPTIONAL)

**i** The mounting rail is attached to the short rail with a cross connector in each case. In order to ensure safe thermal separation, the mounting rails must not be longer than **3 m** in the composite.

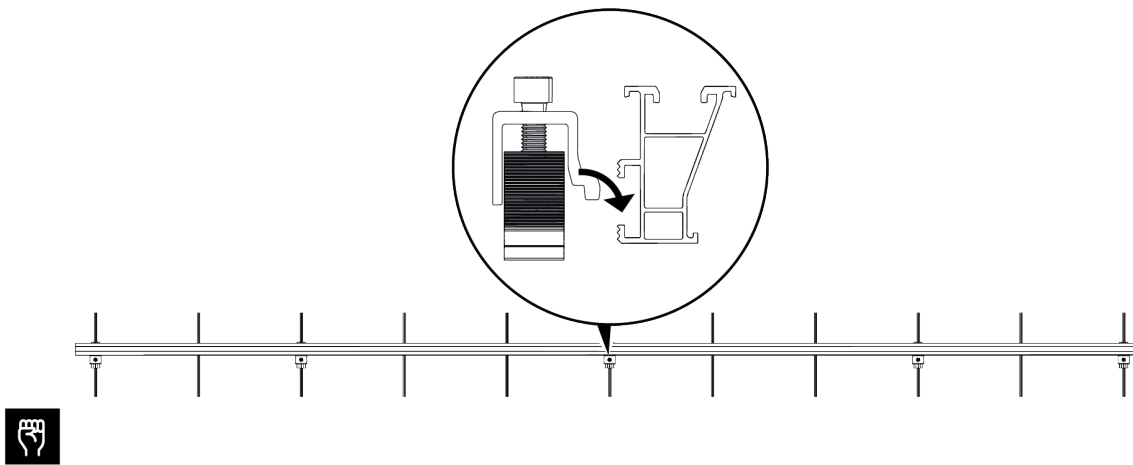

➤ Attach a cross connector to the mounting rail for each short rail in a row.

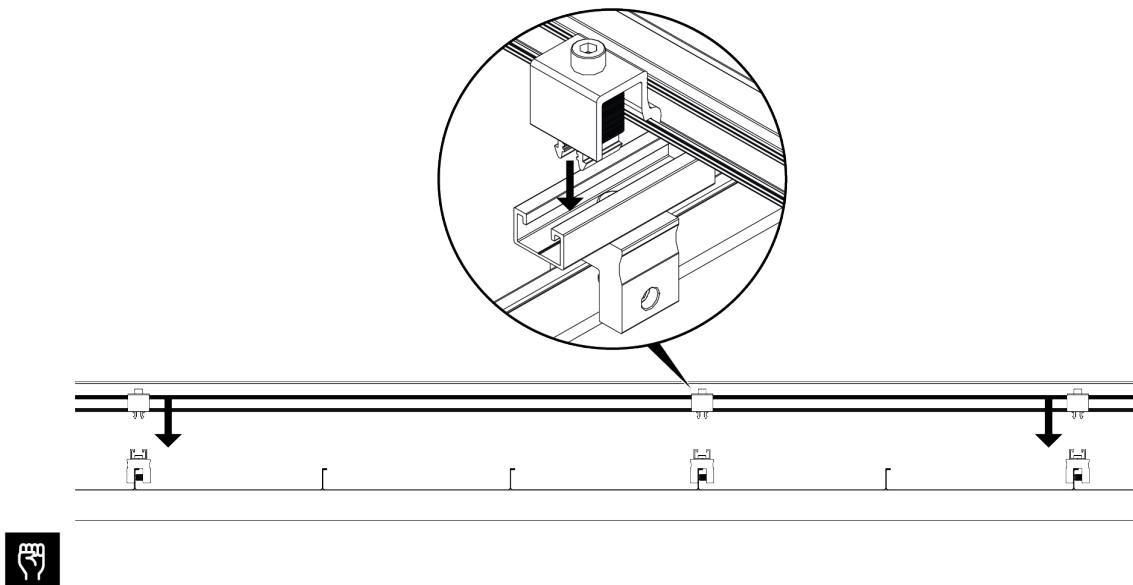

➤ Attach the cross connector to the short rail in each case.



- Make sure that the cross connector is correctly attached.
- Tighten the Allen screw (1) on each of the cross connectors to 15 Nm or 11 ft lb.

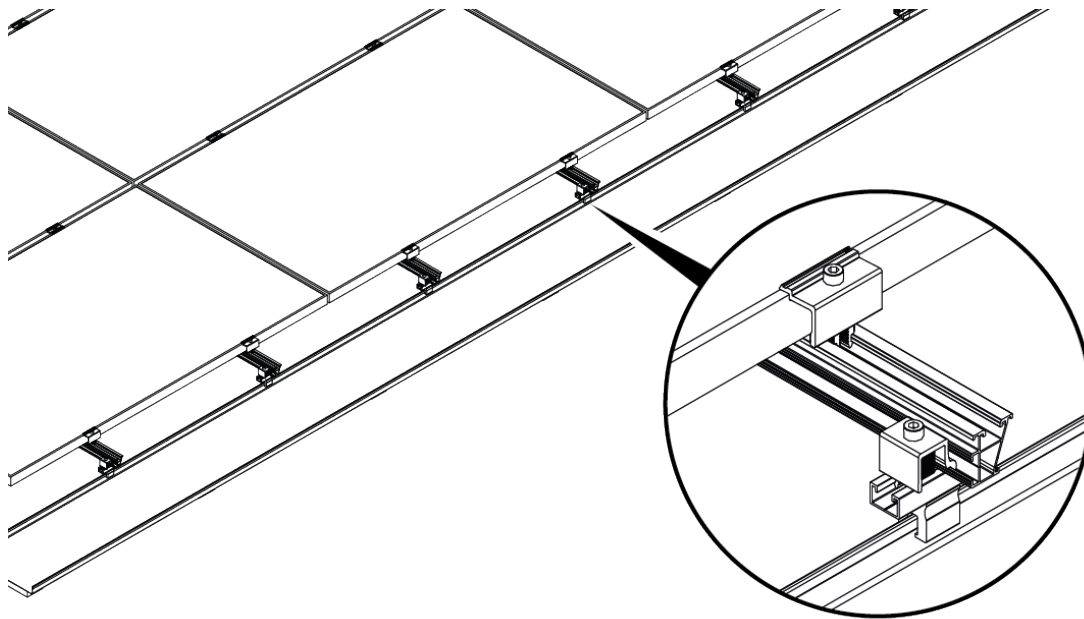

**i** It is important to ensure that the cross connector is mounted on the downhill side.

## MOUNTING MODULES ON MOUNTING RAIL X40/X50

**i** Do not step on the modules when mounting them. Refer to the AEROTOOL report for the exact positions of the module clamps.

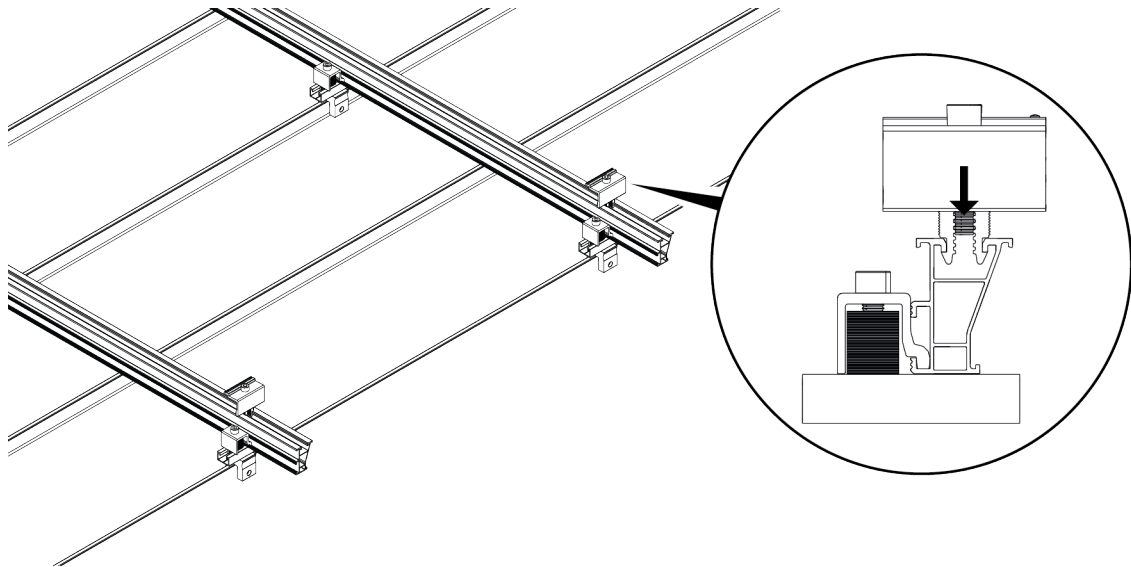

➤ Attach the end clamps to the edge of the module field on the mounting rails.

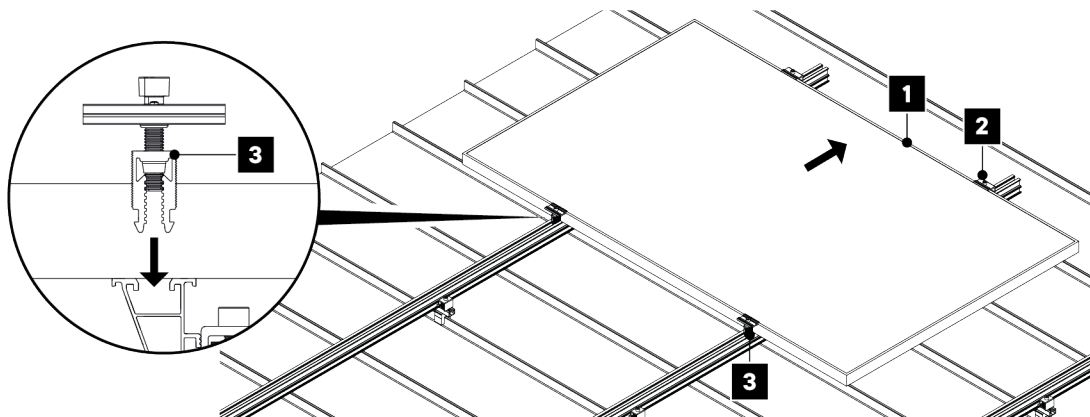

- Place module (1) on top.
- Tighten the screws (2) on the end clamps to 15 Nm or 11 ft lbs.
- Attach center clamps (3) after the first module.

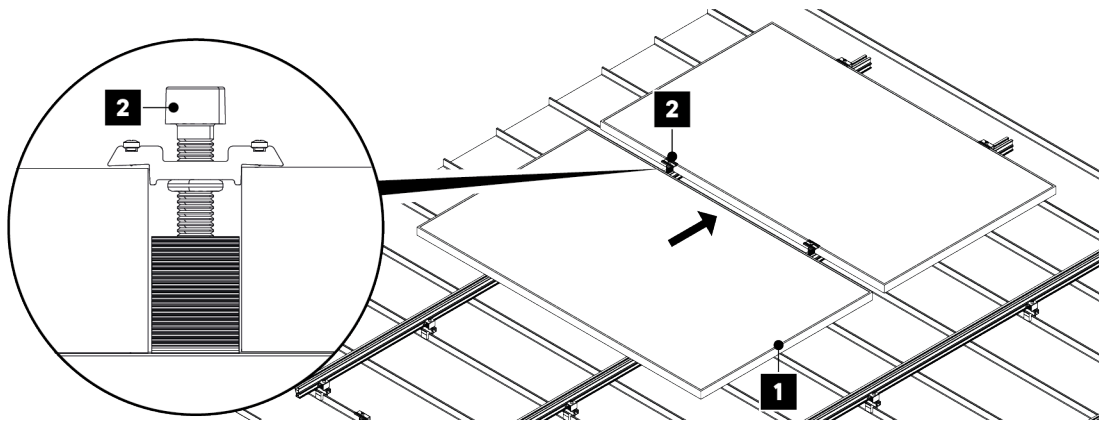

- Place the second module (1) flush against the center clamps.
- Tighten the screws on the middle clamps (2) to 15 Nm or 11 ft lbs.

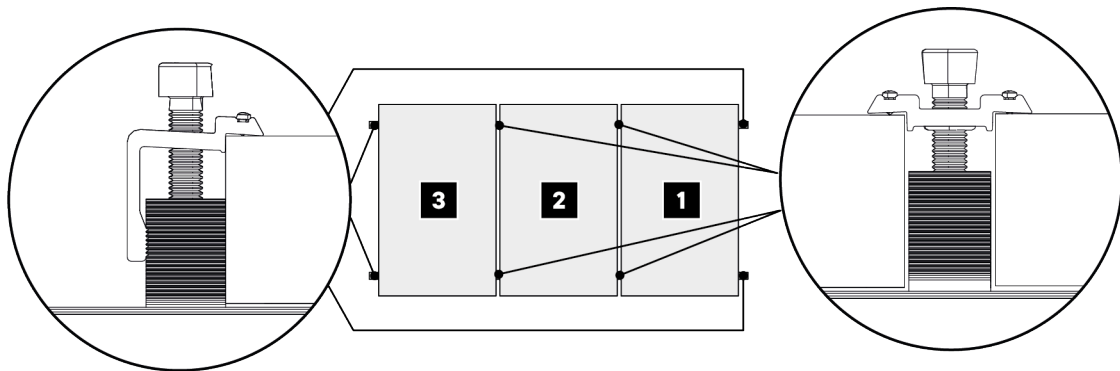

- Lay the modules row by row.
- Make sure that the modules are mounted in a line.
- Tighten the screws on the clamps to 15 Nm or 11 ft lbs each.

#### REPOSITION / REPLACE CLAMPS

- Dismantle the mounted clamp: Unscrew the screw on the clamp completely.
- Depending on the installation situation, press the clamp together at the side and pull it out or pull it out of the rail at the side.

## CABLE MANAGEMENT

### CABLE CLIP CLP-M FOR MODULES

**i** The **CLP-M cable clip** is suitable for module frames with a sheet thickness of **1 - 3 mm**.



#### CLP-M

Cable tie clip for module frames with a thickness of 1 - 3 mm

#### ASSEMBLY



- ▶ Insert the CLP-M (1) into the module frame.
- ▶ The CLP-U is suitable for:
  - Solar plug (e.g. MC4)
  - Solar cable
- ▶ Then tighten the cable tie (2).

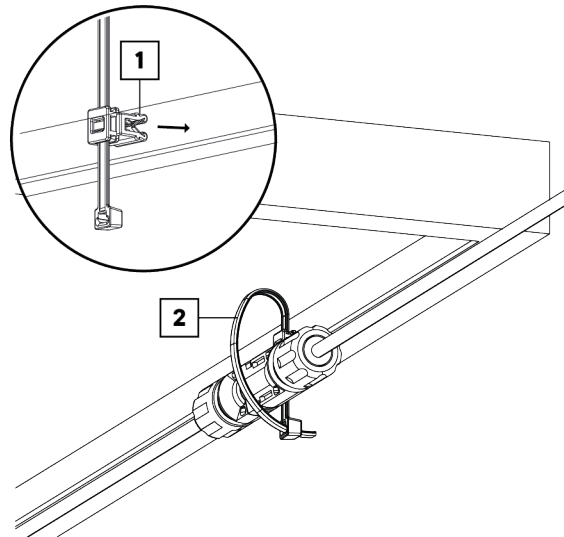

### CABLE CLIP CLP-U FOR MODULES

**i** The **CLP-U cable clip** is suitable for module frames with a sheet thickness of **1.5 - 3 mm**.

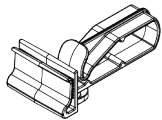

#### CLP-U

Cable clip universal

#### ASSEMBLY



- ▶ Insert the CLP-U (1) into the module frame.
- ▶ The CLP-U is suitable for:
  - A** - Solar connectors (e.g. MC4)
  - B** - Solar wire

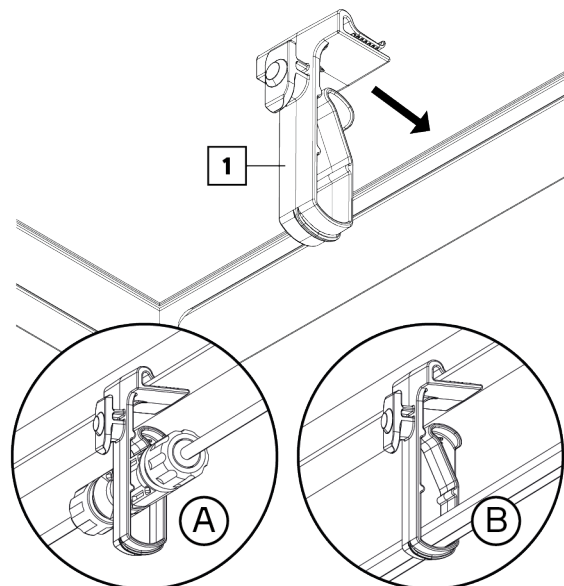

## MLPE FOR MOUNTING MOUNTING RAIL (OPTIONAL)

**i** The **SCR-MA** screw connection is intended for the mounting rails **X40**, **X50** and **X60**. In the following steps, the assembly is shown using an **X40** mounting rail. The procedure is identical for **X50** and **X60** mounting rails.

### NECESSARY COMPONENTS

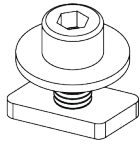

**SCR-MA**  
Bolting set module accessories



**X40-XXXX**  
Mounting rail X40 1980 mm 3300 mm 3550 mm 4400 mm 4750 mm 5500 mm 5850 mm

### ASSEMBLY (EXAMPLE MOUNTING RAIL X40)



- Insert the screw connection (1) into the MLPE device (2) as shown in the illustration.
- Ensure that the plate (3) is pointing downwards.

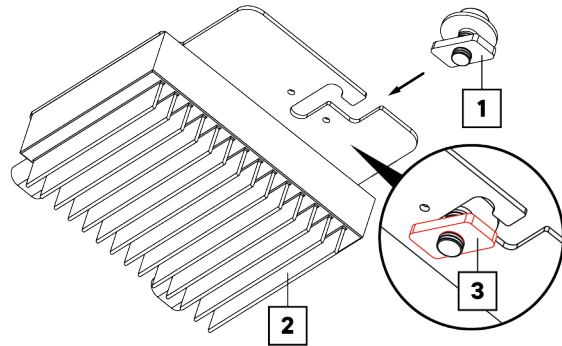

- Guide the MLPE (1) with the screw connection to the top of the mounting rail (2).
- Insert the plate (3) as shown in the illustration.

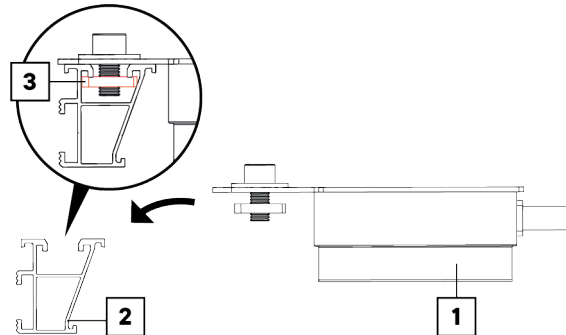

- Then tighten the Allen screw (1) with a torque of 15 Nm or 11 lb-ft.
- ☑ The MLPE is now mounted.

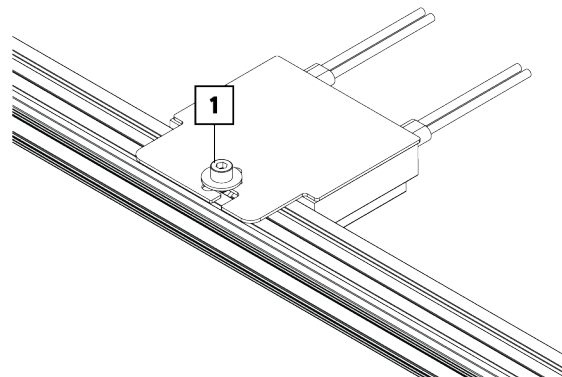



## POTENTIAL EQUALIZATION

**i** For equipotential bonding, **AEROCOMPACT Europe GmbH** provides the wire clamp and aluminum wire as accessories. These are each mounted on the mounting rail, depending on the mounting situation, the module rows are connected to each other by the module clamps.

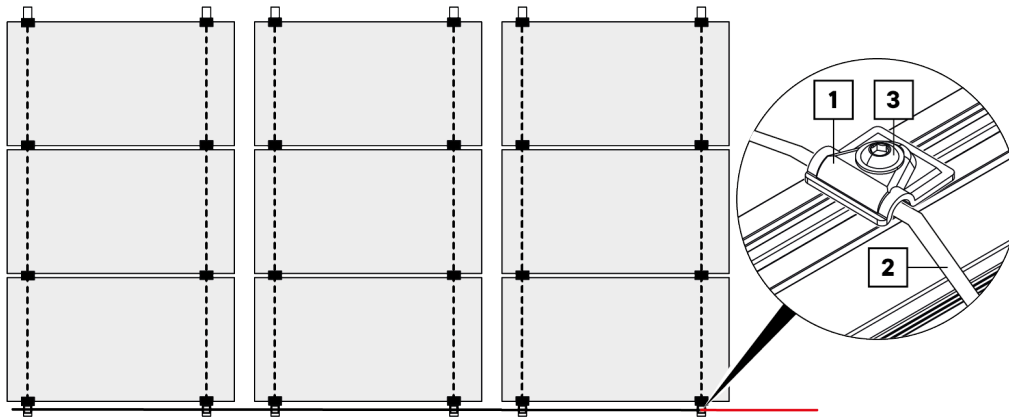

Exemplary representation



**i** Dotted lines - connection by module clamps  
Continuous lines (black) - connection module rows  
Continuous lines (red) - connection of equipotential bonding **on-site**

- ☒ Attach the wire clamp (1) to the mounting rail.
- ☒ Insert the wire (2) at the wire clamp.
- ☒ Tighten the screw (3) with a torque of 10 Nm or 7.37 ft lb.
- ☒ Connect the wire (2) to the on-site equipotential bonding.

# MAINTENANCE, DISASSEMBLY AND DISPOSAL

## MAINTENANCE

To prevent personal injury and damage to property, the system must be checked regularly by qualified personnel and annual maintenance is required.

- Check all system components for damage. In the event of damage, replace the affected component immediately.
- Check all screw connections. Tighten loose screw connections, observing the tightening torque specified in the installation instructions.
- Checking all components for damage caused by the weather, animals, dirt, deposits, build-up, vegetation, roof penetrations, seals, stability and corrosion. In the event of damage, clean, repair or replace the affected component.

---

## DISASSEMBLY

### DISMANTLING THE CLAMPS (EXAMPLE)



**i** To disassemble the system, carry out the assembly steps in reverse order.

- Unscrew the screw (1) on the clamp.
- When reusing the clamp, ensure that the O-ring (2) is not lost.
- i** If the components are reused, it must be noted that these are wearing parts. Therefore, the AEROCOMPACT Europe GmbH cannot assume any responsibility for checking the degree of wear. For this reason, any liability or warranty of AEROCOMPACT Europe GmbH in case of reuse is excluded and reuse is at the installer's own responsibility.

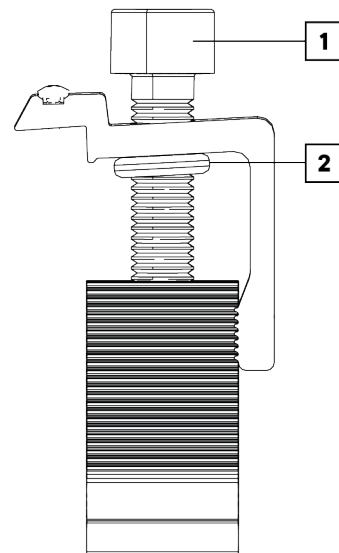

## DISPOSAL

Unless a take-back or disposal agreement has been made, disassembled components should be recycled:

- Give metals and plastic elements for recycling.
- Dispose of remaining components sorted according to material composition.

**i** Incorrect disposal may result in hazards to the environment. In case of doubt, obtain information on environmentally sound disposal from the local municipal authority or from specialized disposal companies.

# APPENDIX

## DECLARATION OF PERFORMANCE



Manufacturer: **AEROCOMPACT Europe GmbH**  
Designation: **CompactMETAL TM standing seam clamping system for metal roofs**  
Identification code: **TMDS08, TMR08, TMM08, TMRD08, TMK1508, TMK2008**  
Applied standard: **EN 1090**  
Certification body: **2397**



[For the declaration of performance](#)

## REVISION HISTORY

Version	Chapter	Modification
v3.4	"Cable management" on page 23	New chapter added

---

**Europe / APAC**

AEROCOMPACT® Europe GmbH  
Gewerbstraße 14  
6822 Satteins  
Austria  
phone: +43 5524 22 566  
e-mail: [office@aerocompact.com](mailto:office@aerocompact.com)

**USA / Canada**

AEROCOMPACT® Inc.  
901A Matthews Mint Hill Road  
Matthews, NC 28105  
USA  
phone: +1 800 578 0474  
e-mail: [office.us@aerocompact.com](mailto:office.us@aerocompact.com)

**India**

AEROCOMPACT® India Private Ltd.  
Hub and Oak  
C-360, Defence Colony  
New Delhi, 110024  
phone: +91 888 26 32 902  
e-mail: [office.in@aerocompact.com](mailto:office.in@aerocompact.com)

---

