

---

Assembly Instruction

## COMPACTPITCH XW

Version : 3.3

Language : English

Important! Read carefully before installation!

---



## **Legal Notice**

Subject to change due to technical modifications! These assembly instructions correspond to the technical status of the delivered product and not to the current development status at the manufacturer. If pages or parts of the assembly instructions are missing, please contact the manufacturer's address given below. The original language of these assembly instructions is German. Any assembly instructions in another language are a translation of the assembly instructions in German. Therefore, in case of doubt or contradiction, the authentic German version shall prevail. The installation instructions are protected by copyright. The installation instructions may not be copied, reproduced, microfilmed, translated or converted for storage and processing in computer systems, either in part or in full, without the written permission of AEROCOMPACT Europe GmbH

Copyright by AEROCOMPACT Europe GmbH

## **Manufacturer**

AEROCOMPACT Europe GmbH  
Gewerbestrasse 14  
6822 Satteins, Austria

[office@aerocompact.com](mailto:office@aerocompact.com)  
[www.aerocompact.com](http://www.aerocompact.com)

## **Creation date**

10/2024

# TOC

---

<b>General</b> .....	<b>4</b>
Applicable documents .....	4
Limitation of liability .....	4
Explanation of symbols .....	4
<b>Safety</b> .....	<b>5</b>
Appropriate use .....	5
Personnel requirements .....	6
Working safely .....	6
Breakthrough protection .....	7
Personal protective equipment (PPE) .....	7
<b>System Overview</b> .....	<b>8</b>
Basic components .....	8
System accessories .....	9
Mounting rails and accessories .....	9
Module accessories .....	9
Accessories for equipotential bonding .....	9
<b>Assembly</b> .....	<b>10</b>
Assembly preparation .....	10
Required tools for assembly .....	10
Measure the area .....	11
XW Mount hanger bolts .....	12
Mount and align angle adapter .....	13
Mount mounting rail .....	14
Hanger bolts XW with hammerhead screw .....	14
Hanger bolts XW with click-quick mounting attachment .....	15
Assembly modules .....	16
Assembly sequence of the modules .....	16
Cable management .....	20
MLPE module mounting (optional) .....	24
MLPE for mounting Mounting rail (optional) .....	25
Potential equalization .....	26
<b>Maintenance, disassembly and disposal</b> .....	<b>28</b>
Maintenance .....	28
Disassembly .....	28
Disposal .....	28
<b>Appendix</b> .....	<b>29</b>
Declaration of performanceXW .....	29
Revision history .....	29

# GENERAL

These assembly instructions describe the assembly procedure and must be strictly adhered to. Read these installation instructions carefully before starting installation. The basic prerequisite for safe working is compliance with all the safety and handling instructions in these installation instructions. In addition, the local accident prevention regulations and general safety regulations for the area of application of the product apply. Illustrations in these instructions are for basic understanding and may differ from the actual design.

## APPLICABLE DOCUMENTS

In addition to this manual, you have received an AEROTOOL project report, planning documents and drawings. Always comply with the instructions and notes contained therein.

## LIMITATION OF LIABILITY

All information and instructions in these assembly instructions have been compiled taking into account the applicable standards and regulations, the state of the art and our many years of knowledge and experience. Liability provisions are stated in our **terms** and can be accessed at [www.aerocompact.com/downloads](http://www.aerocompact.com/downloads).

## EXPLANATION OF SYMBOLS

### SYMBOLS FOR INSTRUCTIONS



Prerequisites for action instruction



Results of action steps



Step by step action instruction



This note provides useful information for smooth installation

### SYMBOLS IN ILLUSTRATIONS - ACTIVITIES



Optional component, optional mounting variation



Activity by hand



Check AEROTOOL project report or planning documents



Visual inspection



Observe right angle

### SYMBOLS IN ILLUSTRATIONS - TOOLS



Measuring tape, measure



Pencil, mark



Chalk line



Scissors, tin snips, cut to size



Cordless screwdriver, screwdriver



Use a torque wrench, Observe torque



Use Allen key

# SAFETY

The following list serves as an indication of the most common safety risks that can occur when installing these products. There is no liability for the completeness of the risks presented. A specific check of the necessary safety measures must be carried out by an authorized specialist company before installation.

## APPROPRIATE USE

The COMPACTPITCH XW system is intended exclusively for the installation of PV modules on corrugated fiber cement roofing or similar roof coverings. Proper use also includes correct installation in accordance with these installation instructions. The COMPACTPITCH XW system can be used in combination with suitable metal roof tiles on slate roofs. The metal tile purchased on site must be installed in accordance with the manufacturer's instructions. The installer is responsible for the watertight installation of Aerocompact products with third-party products; this is the only way to ensure that the roof is watertight for both systems. Approval from the module manufacturer is required for the use of PV modules with the COMPACTPITCH XW system. AEROCOMPACT accepts no liability for loss of performance or damage of any kind to the PV modules. Any other use of the COMPACTPITCH XW system is considered improper use.

## ENSURING TIGHTNESS DURING INSTALLATION

**I** The following instructions are essential to ensure that the roof is watertight during the installation of roof hooks and hanger bolts and to prevent subsequent damage due to leaks.

**Correct positioning:** Roof hooks and hanger bolts must be positioned exactly in accordance with the planning documents and local building regulations. Incorrect positioning can impair the roof waterproofing and lead to water ingress. It is particularly important to look out for sharp-edged or protruding noses on roof tiles, which may need to be removed to ensure tightness - this applies especially when using replacement roof tiles.

**Correct torque setting:** Great care must be taken when tightening the fastening screws of both the roof hooks and the hanger bolts. Excessive tightening can damage the roof waterproofing and cause leaks. It is essential to adhere exactly to the torques specified in these installation instructions in order to maintain the structural integrity of the roof and the seal.

**Final check and inspection:** After the roof hooks and hanger bolts have been installed, a comprehensive inspection of the installed components must be carried out. Pay attention to damage to sealing materials or potential leaks. Incorrect installation can cause serious consequential damage to the building fabric and interior fittings.

**Legal notice:** By adhering to these installation instructions, responsibility is assumed for the correct installation of roof hooks and hanger bolts in accordance with regulations. Damage, in particular due to improper installation and resulting leaks, may result in liability claims. Careful observance of these recommendations makes a decisive contribution to the longevity and tightness of the roof.

## PERSONNEL REQUIREMENTS

Installation may only be carried out by a specialist company and must be carried out strictly in accordance with the installation instructions, the project report and the planning documents. A specialist company is a company that is familiar with the installation and maintenance of photovoltaic systems as part of its normal business operations. National and local building regulations, standards and environmental protection must be complied with. Under no circumstances may the assembly personnel be under the influence of medication, alcohol, drugs or in any other condition that impairs consciousness (e.g. overtiredness). Trainee personnel may only carry out work under the instruction and supervision of specialist personnel who are authorized to train personnel.

## WORKING SAFELY

The contractual partner must ensure that the necessary safety measures and the relevant labor law and occupational safety regulations are observed when installing products from AEROCOMPACT Europe GmbH. Information from AEROCOMPACT Europe GmbH on the need to comply with security measures is provided without guarantee and without any claim to completeness and serves only to support the contractual partner. The contractual partner is obliged to inform himself about all relevant regulations concerning working safety and to comply with them. AEROCOMPACT Europe GmbH expressly assumes no responsibility and consequently no liability. Areas below the roof on which work is being carried out must be protected from falling objects. Where this is not possible, the affected areas must be closed to the public and unauthorized personnel. If the weather is unsuitable, work on the roof must not be continued for longer than necessary or must not be started at all. Never carry out installation work in strong winds. Strong winds exert particular enormous forces on the large-area PV modules. There is a risk of a module being torn off the roof and people being injured. Never work in wet conditions or at temperatures below freezing. Depending on the roof pitch, there is a risk of slipping. Only use suitable, intact and tested ladders. Set up and secure ladders according to specifications. Separate rules apply to mechanical climbing aids (elevators, cherry pickers, etc.). Never use the PV mounting system as a climbing support. Keep sufficient distance from overhead power lines. Equipotential bonding between the individual system components must be carried out in accordance with the respective country-specific regulations. When cutting materials to size, make sure there are no burrs, especially on edges and corners where there is a risk of injury.

# BREAKTHROUGH PROTECTION

Roof windows, skylights, large ventilation flaps, etc. generally cannot withstand the weight or impact of a person. Such objects must be secured in a similar way to the roof edge. Corrugated fiber-cement roofs can be at risk of breakthrough over the entire surface. Define routes and secure them with load distribution measures. Always use load distribution aids on roof coverings or roof structures (e.g. thin sheet metal, corrugated fiber cement) with insufficient load-bearing capacity.

# PERSONAL PROTECTIVE EQUIPMENT (PPE)

Personal protective equipment is used to protect people from health and safety hazards at work. Personnel must wear personal protective equipment during installation. Personal protective equipment is explained below:



**Wear safety goggles when drilling and sawing**



**Wear cut-resistant work gloves during assembly**



**Wear safety shoes**



**Use fall protection**



**Helmets must be worn by all persons working on the construction site**



**Wear hearing protection**

# SYSTEM OVERVIEW

## BASIC COMPONENTS

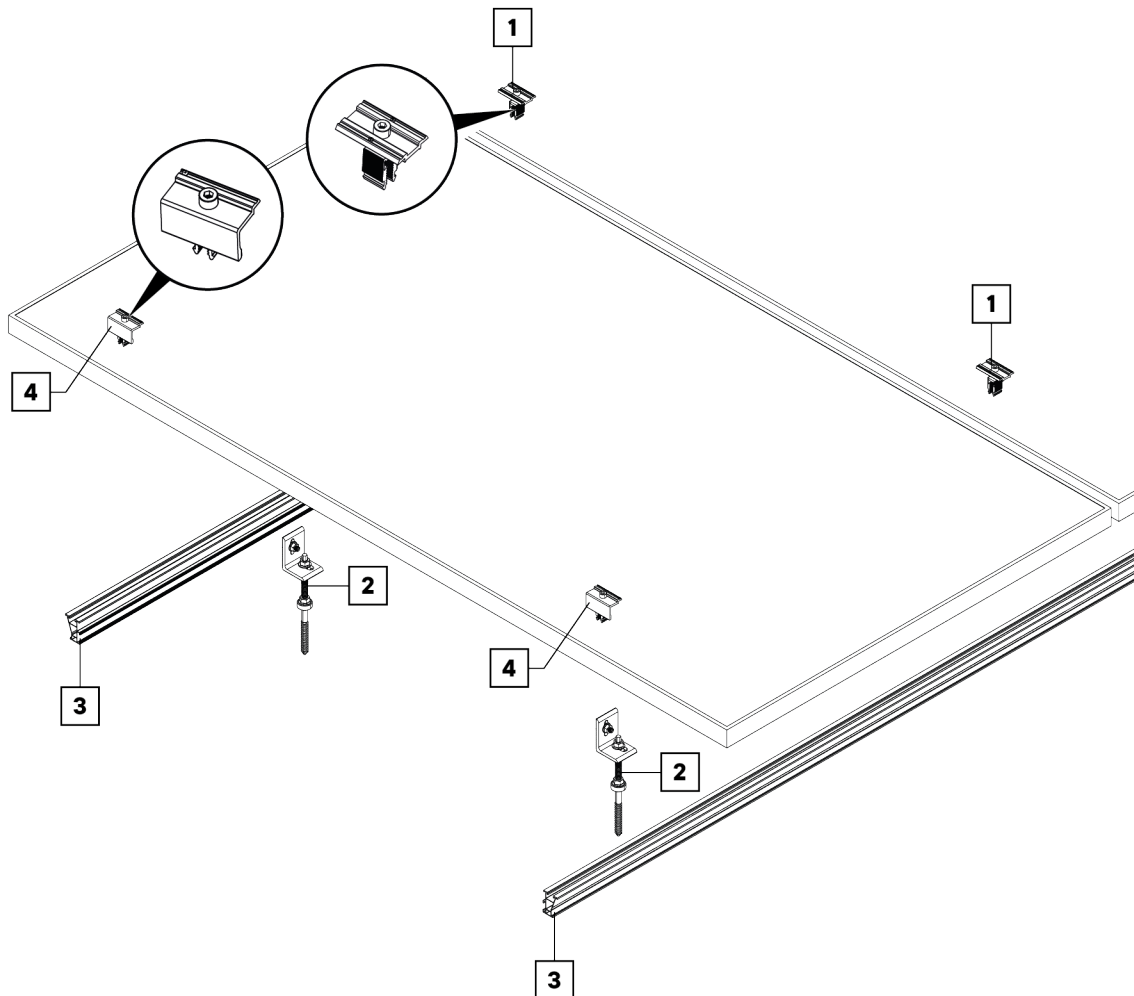

**1 CLM10**

Middle clamp Click 30 - 46 mm

**3 X40**

Mounting rail X40 | 1980 mm | 3300 mm | 3550 mm |  
4400 mm | 4750 mm | 5500 mm | 5850 mm

**2 XW10XXXCL | XW12XXXCL**

Hanger bolt M10 (250, 300) | M12 (200, 250, 300)

**4 CLE10**

End clamp Click 30-46



## SYSTEM ACCESSORIES



**XW**  
M10 x 180 - 300 mm | M12 x 200 - 300 mm  
XW10180 - XW10300 | XW12200 -  
XW12300



**XWCL**  
M10 x 200 - 300 mm | M12 x 200 - 300 mm  
XW10200CL - XW10300CL | XW12200CL -  
XW12300CL

## MOUNTING RAILS AND ACCESSORIES

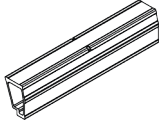

**XPCN60**  
Rail connector X60



**XPCN-XX**  
Rail connector X40, X50

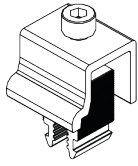

**XDL**  
Cross connector X40, X50, X60

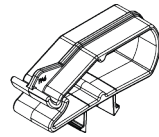

**CLP-R**  
Cable clip rail

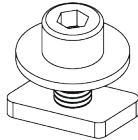

**SCR-MA**  
Bolting set module accessories

## MODULE ACCESSORIES

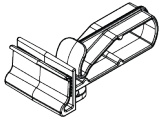

**CLP-U**  
Cable clip universal

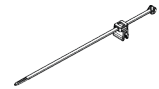

**CLP-M**  
Cable tie clip for module frames with a  
thickness of 1 - 3 mm

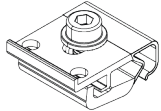

**OC-GA**  
Microinverter clamp universal

## ACCESSORIES FOR EQUIPOTENTIAL BONDING

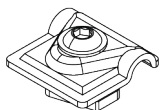

**WCL8-10**  
Wire clamp 8 - 10 mm

# ASSEMBLY

## ASSEMBLY PREPARATION

### Required tools for assembly

**i** Before starting the assembly, make sure that the assembly personnel are familiar with the proper use of the listed tools.



**Bit hexagon socket 6 mm**



**Bit TORX T40**



**Torque wrench 10 - 30 Nm with hexagon socket bit 6mm**

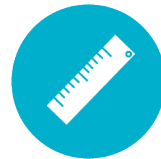

**Measuring tape**



**Cordless screwdriver**



**Torque wrench 10 - 30 Nm with socket for WS 13**



**Open-end wrench SW15**

## MEASURE THE AREA

**i** The hanger bolts are positioned as centered as possible on top of the crest and attached as straight as possible.

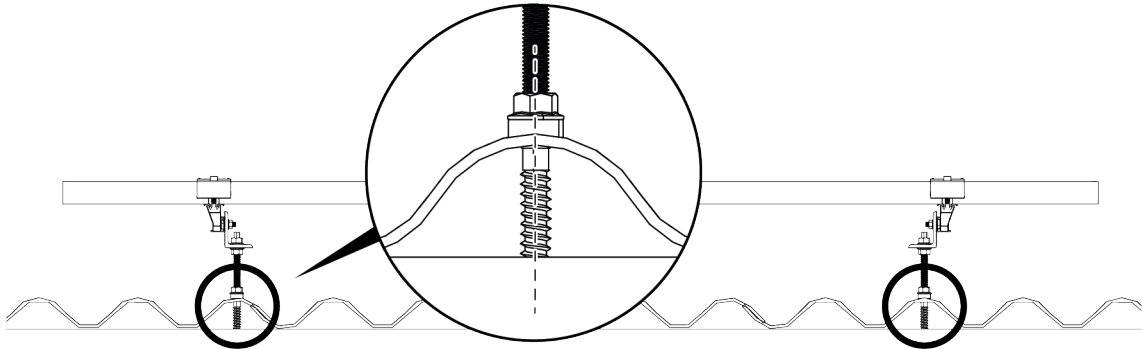

**i** The hanger bolts are screwed to the roof purlins and/or rafters (see AEROTOOL planning documents).

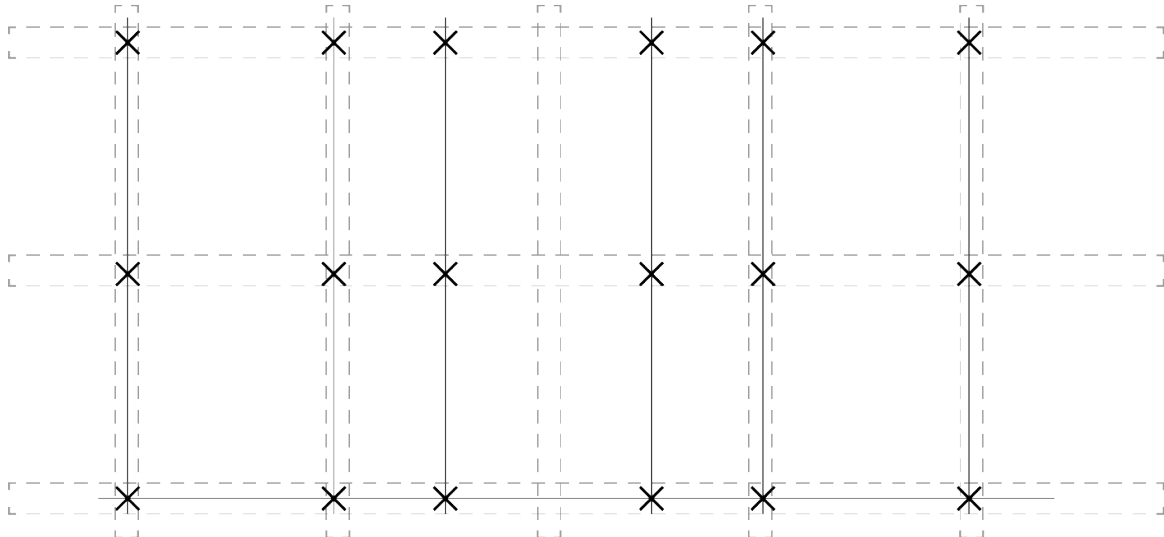

- Refer to the dimensions of the module field from the AEROTOOL planning documents.
- Determine module size.
- Determine the distances between the rafters
- Determine and mark the positions of the hanger bolts.

## XW MOUNT HANGER BOLTS

**i** The hanger bolts can be installed on slate roofs in combination with suitable metal roof panels. For the metal roof panels, make sure that the sealing level is higher than the water-bearing level. The metal roof panels are provided by the customer. Only qualified personnel may install the metal roof panels together with the hanger bolts. Only in this way can ensure tightness of the roof.

**⊠** If the fastening screw of the roof covering overlaps with the position of the hanger bolt: Remove fastening screw.



**⊠** Pre-drill holes at the marked positions:

M10 hanger bolt: Pre-drill wood rafters:  $\varnothing$  7 mm, roofing material  $\varnothing$  13 mm.

M12 hanger bolt: Pre-drill wood rafter:  $\varnothing$  8.4 mm, roofing material  $\varnothing$  15 mm.

**⊠** Screw in the hanger bolts slowly and straight.

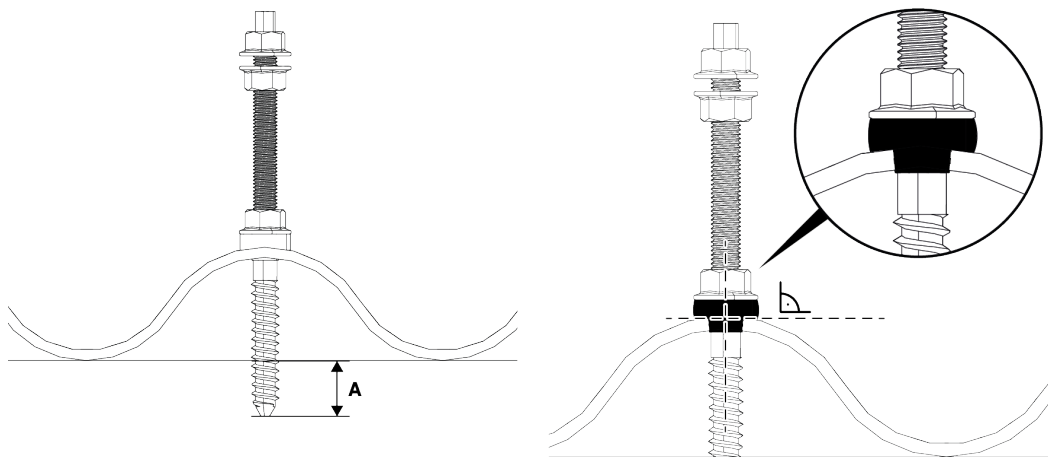

**⊠** Observe the minimum screw-in depth of the thread (A) in the load-bearing timber:

Hanger bolt M10: at least **40 mm**

Hanger bolt M12: at least **48 mm**

**⊠** Tighten the lower nut until the rubber seal bulges slightly outward (tightening torque: 15 Nm or 11 lb-ft).

## Mount and align angle adapter

XW



- Remove the nut (2) and guide the angle adapter.
- **Align the universal adapter:**  
Loosen and tighten nuts (2) and (3) until the desired position is reached.
- Align all angle adapters at the same height.

**i** Small height differences can be compensated with the nut (1) on the hammerhead bolt.

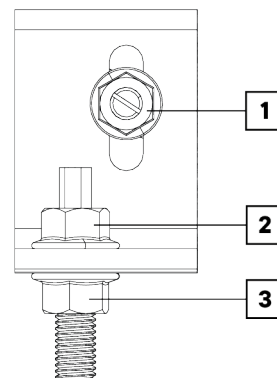

XWCL



- Remove the nut (2) and guide the angle adapter.
- **Align the universal adapter:**  
Loosen and tighten nuts (2) and (3) until the desired position is reached.
- Align all angle adapters at the same height.

**i** Small height differences can be compensated for with the screw (1) on the click-quick mounting attachment.

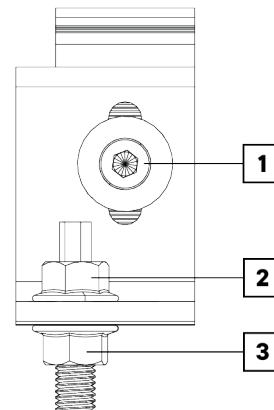

## MOUNT MOUNTING RAIL

### Hanger bolts XW with hammerhead screw

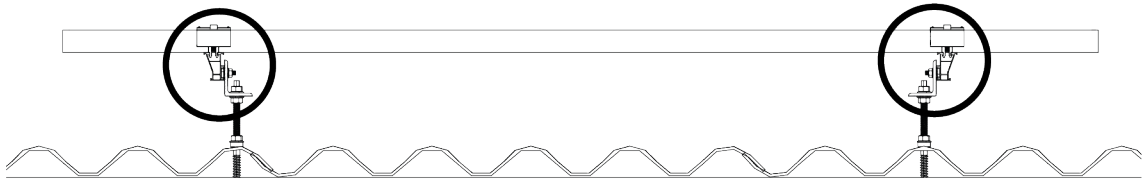

**i** Make sure that the universal adapters per module row are each aligned inwards.

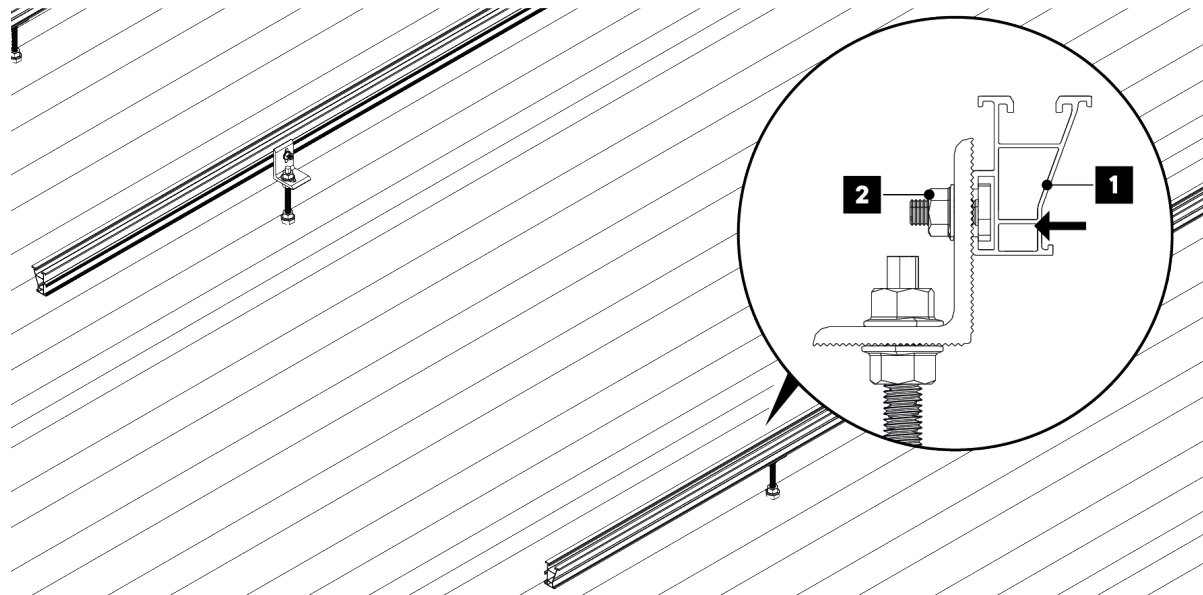

- ▷ Fasten the mounting rail (1) with the hammerhead screw in each case.
- ▷ Tighten the nuts (2) with a torque of 15 Nm or 11 lb-ft.

### FITTING THE HAMMER-HEAD BOLT



**i** The notch must be aligned vertically as shown in the illustration. Create a force-fit and form-fit connection between the screw and the mounting rail.

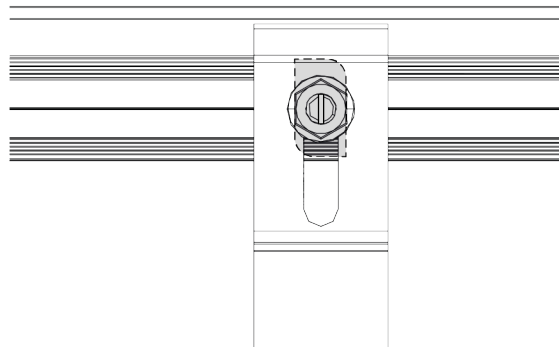

# Hanger bolts XW with click-quick mounting attachment

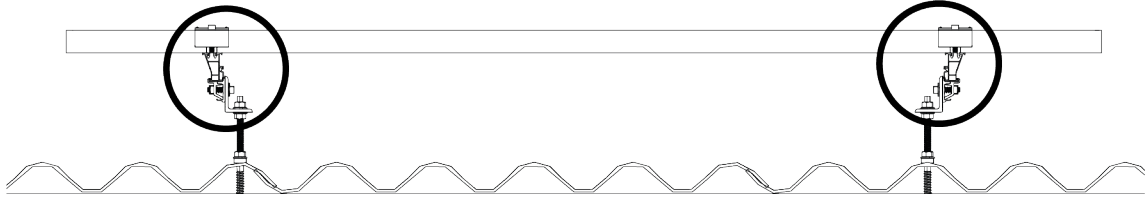

**i** Make sure that the universal adapters in a module row are each aligned inwards.

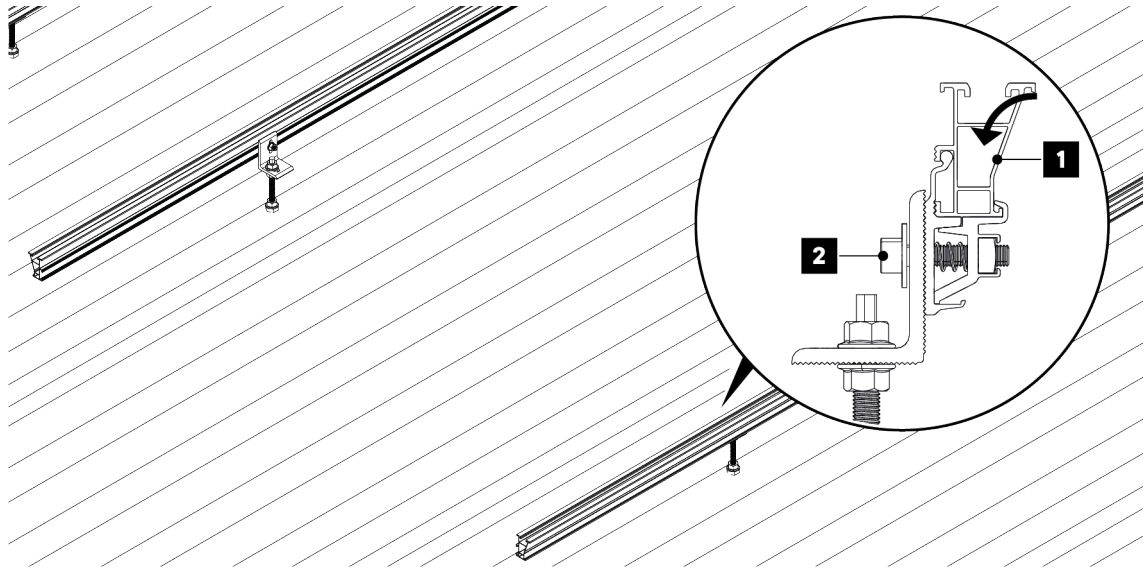

- ▶ Attach the mounting rail (1) to the quick mounting attachment in each case.
- ▶ Tighten the screw (2) with a torque of 15 Nm or 11 lb-ft.

## ASSEMBLY MODULES

### Assembly sequence of the modules

**i** The following illustration is an example and may show a different number of modules and ballast trays depending on the project. The module assembly sequence remains constant. The **assembly sequence** is crucial to avoid deformation of the starting brackets, connectors and end brackets.

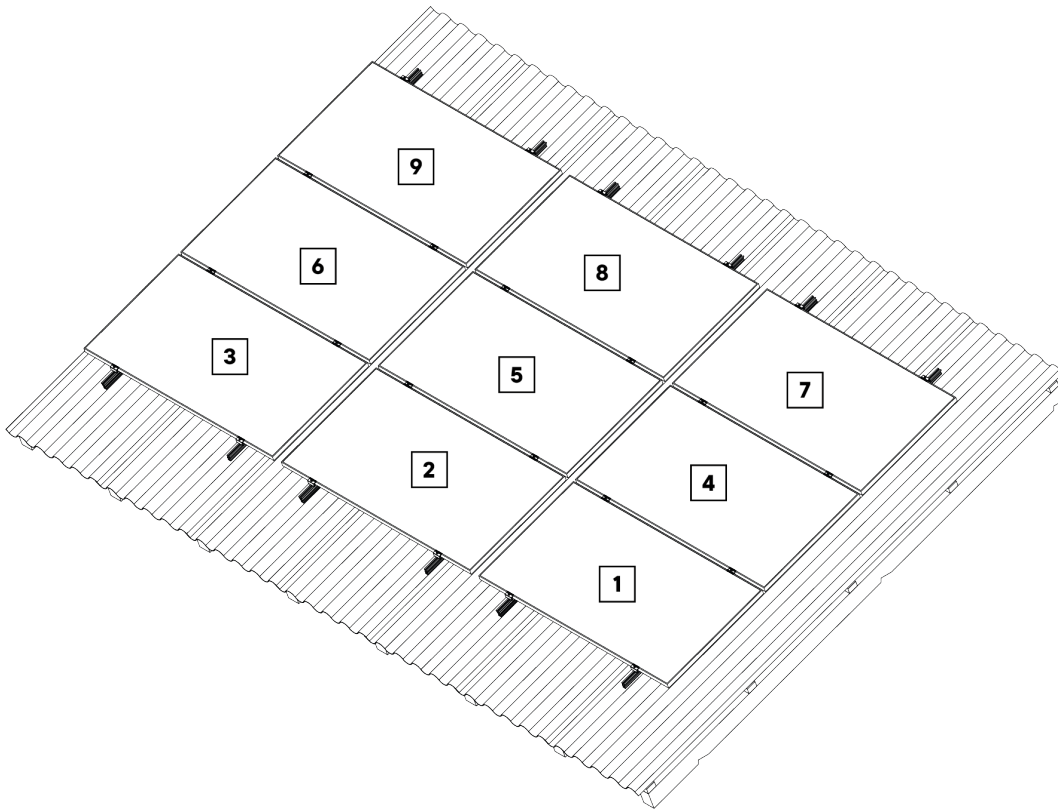

**➤** The modules must be installed in ascending order from **1** to **9**.

#### RECOMMENDATION FOR MODULE INSTALLATION



**i** **Installation tip:**

Before starting the module installation, install two CLP-U per module as shown in the illustration to ensure better accessibility for the subsequent cabling.

**➤** If necessary, slide the CLP-U cable clips out of the clamping area.

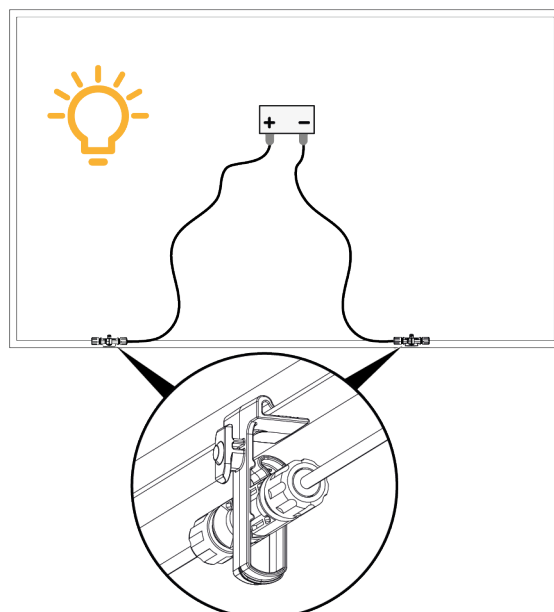



## INSTALLING END CLAMPS IN THE FIRST ROW

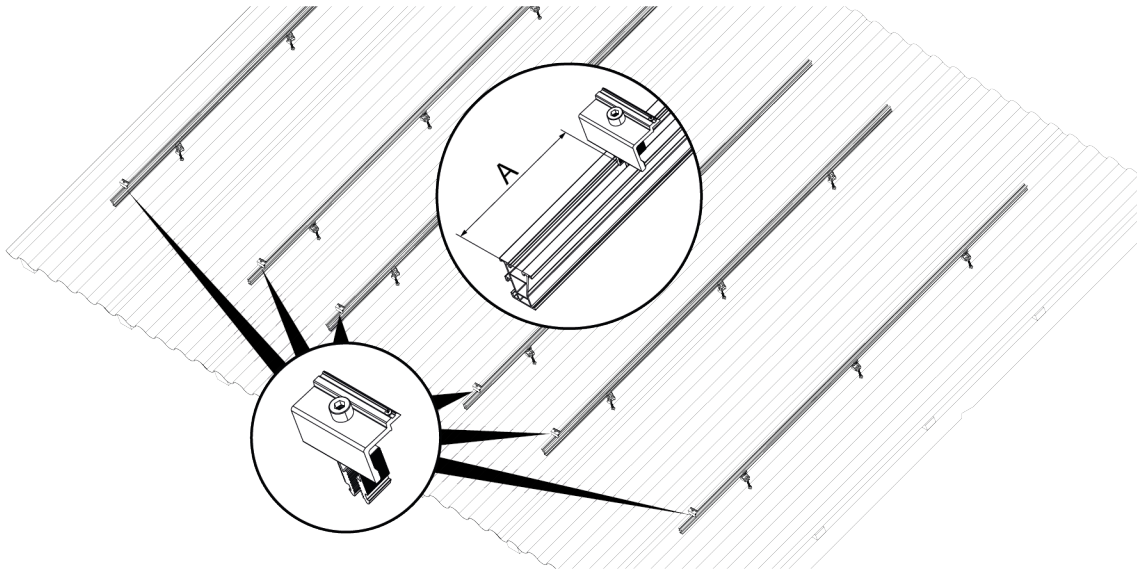

- ▶ Attach the end clamps to the lower edge of the mounting rail - **2 to 3 threads, do not screw tight.**
- ▶ The edge distance of the end clamp is **A = 40 mm.**

## INSTALLING THE FIRST ROW



- ▶ Position the module (1) so that the end clamps (2) are flush with the module.

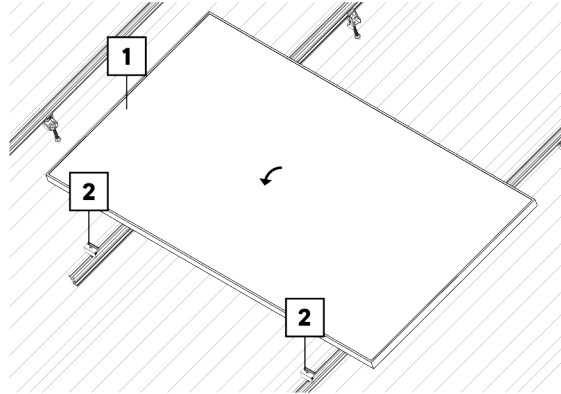

- ▶ Tighten the end clamps (1) with a torque of 15 Nm or 11 lb-ft.
- ▶ Attach the middle clamps (2) on the opposite side of the module to the mounting rail - **2 to 3 threads, do not screw tight.**

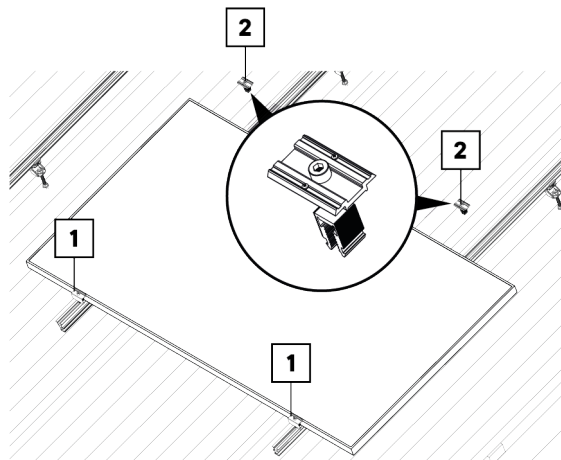

- ▶ Position the second module (1) so that the end clamps (2) are flush with the module.

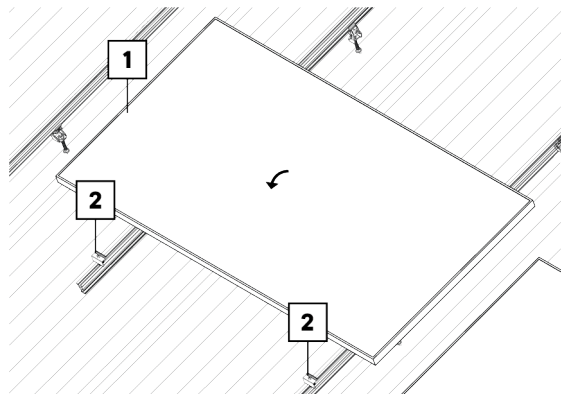



- ▶ Tighten the end clamps (1) with a torque of 15 Nm or 11 lb-ft.
- ▶ Attach the middle clamps (2) on the opposite side of the module to the mounting rail - **2 to 3 threads, do not screw tight.**

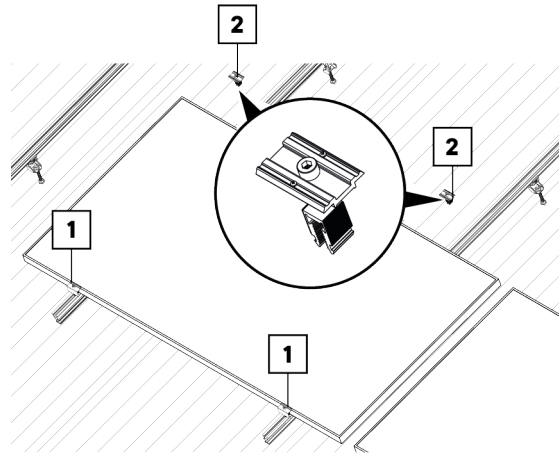

- ▶ Position the third module (1) so that the end clamps (2) are flush with the module.

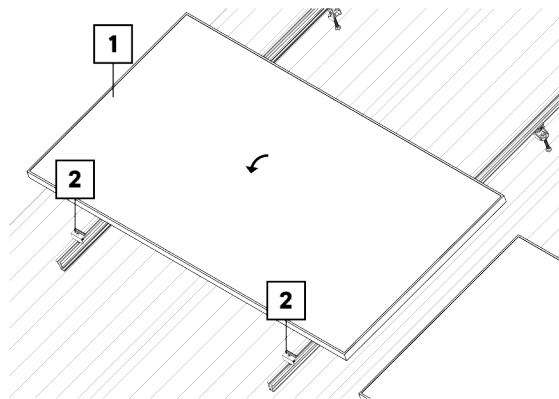

- ▶ Tighten the end clamps (1) with a torque of 15 Nm or 11 lb-ft.
- ▶ Attach the middle clamps (2) on the opposite side of the module to the mounting rail - **2 to 3 threads, do not screw tight.**

**i** Install the other module rows in the **same sequence.**

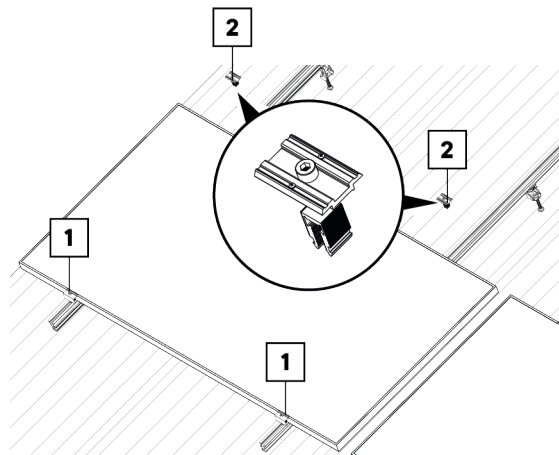

## CABLE MANAGEMENT

### CABLE CLIP CLP-M FOR MODULES

**i** The **CLP-M cable clip** is suitable for module frames with a sheet thickness of **1 - 3 mm**.



#### CLP-M

Cable tie clip for module frames with a thickness of 1 - 3 mm

#### ASSEMBLY



- ▶ Insert the CLP-M (1) into the module frame.
- ▶ The CLP-U is suitable for:
  - Solar plug (e.g. MC4)
  - Solar cable
- ▶ Then tighten the cable tie (2).

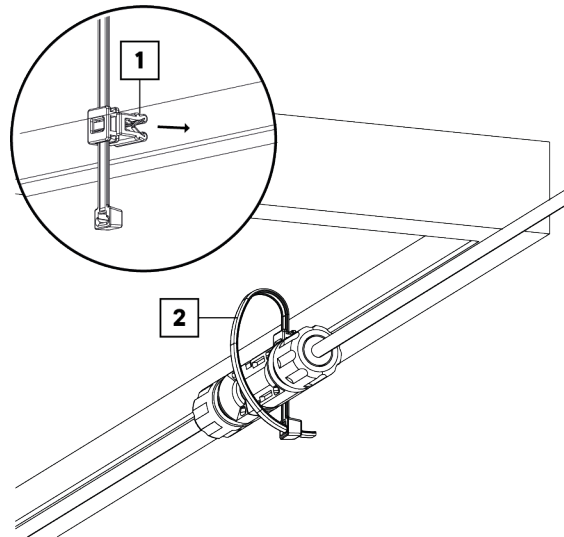

### CABLE CLIP CLP-U FOR MODULES

**i** The **CLP-U cable clip** is suitable for module frames with a sheet thickness of **1.5 - 3 mm**.

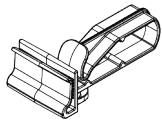

#### CLP-U

Cable clip universal

#### ASSEMBLY



- ▶ Insert the CLP-U (1) into the module frame.
- ▶ The CLP-U is suitable for:
  - A** - Solar connectors (e.g. MC4)
  - B** - Solar wire

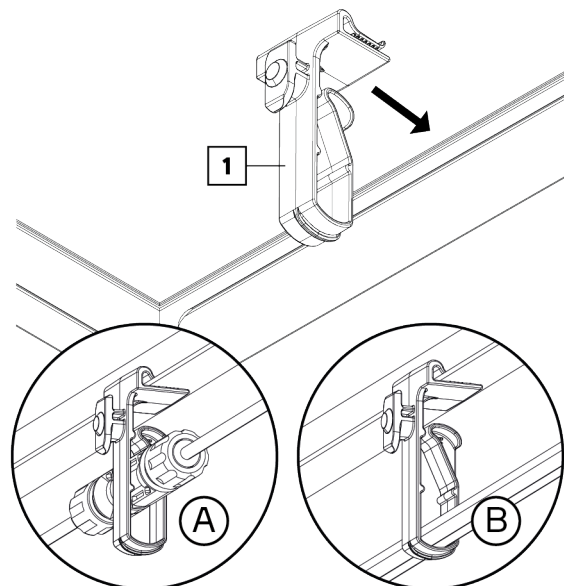

## MOUNT THE CLP-U CABLE CLIP TO THE MOUNTING RAIL



- Insert the cable clip (1) into the mounting rail (2) from above.
- Rotate the cable clip by 90°.

### **i Attention:**

Make sure that the cable clip is fully engaged in the rail channel.

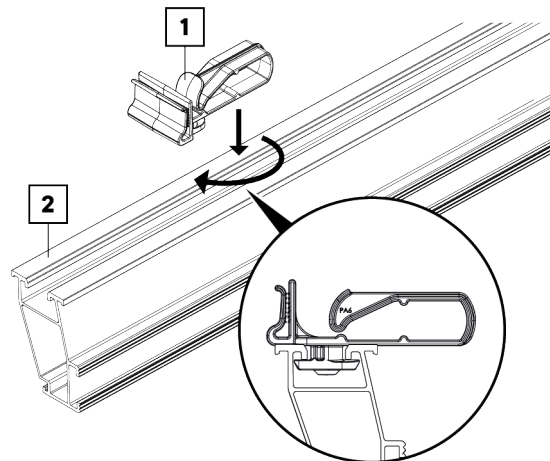

- The CLP-U (1) is suitable for:
  - A** - Solar connectors (e.g. MC4)
  - B** - Solar wire

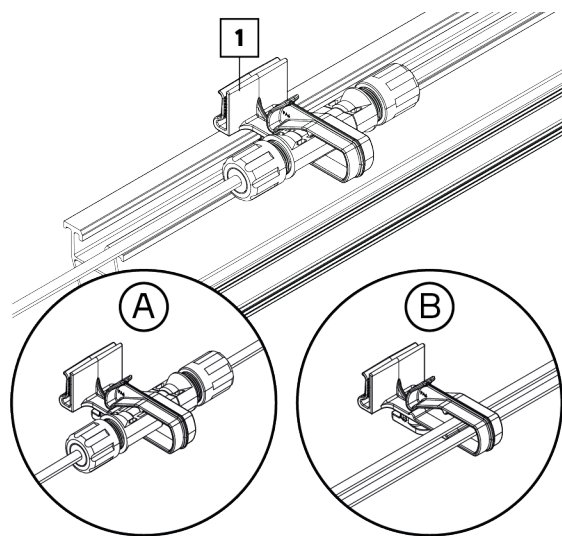

## MOUNT THE CLP-U CABLE CLIP ON THE SIDE OF THE MOUNTING RAIL



- Guide the cable clip (1) to the side of the mounting rail (2).
- Rotate the cable clip by 90°.

### **1 Attention:**

Make sure that the cable clip is fully engaged in the rail channel.

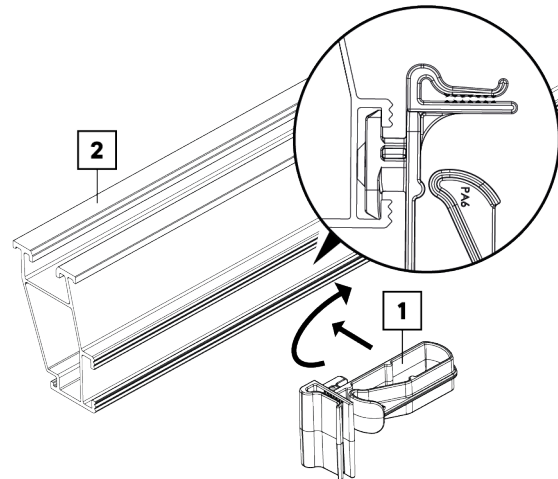

- The CLP-U (1) is suitable for:
  - A** - Solar connectors (e.g. MC4)
  - B** - Solar wire

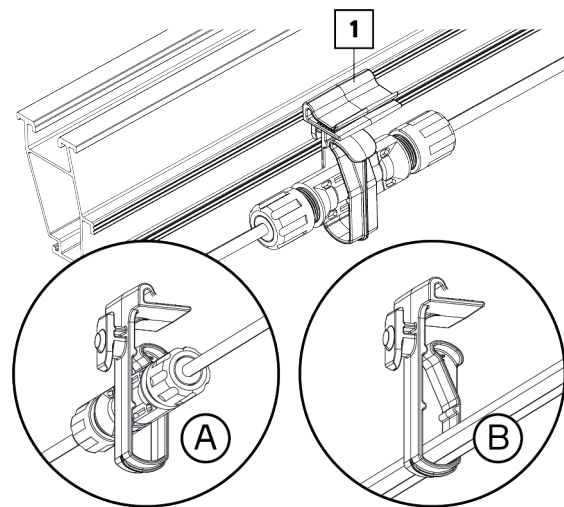

## MOUNT THE CLP-R CABLE CLIP TO THE MOUNTING RAIL

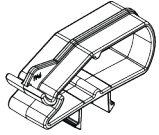

**CLP-R**  
Cable clip rail

## MOUNT THE CLP-R



- ▶ Click the cable clip (1) into the mounting rail (2) from above.
- ▶ Insert the solar plug (3) from the side.

### **i Attention:**

Make sure that the cable clip is fully engaged in the rail channel.

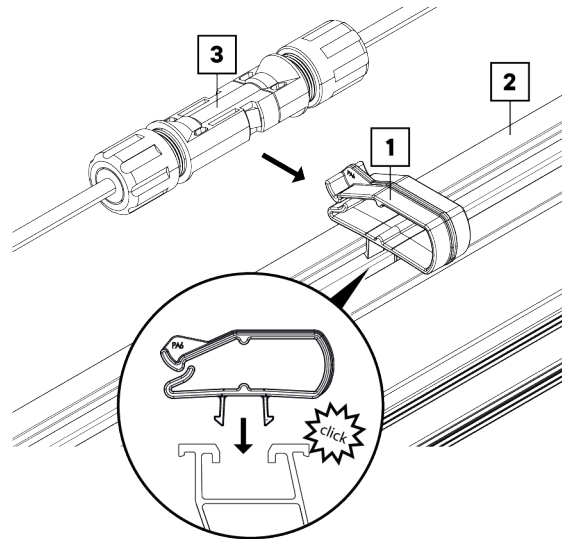

- ▶ The CLP-R (1) is suitable for:
  - A** - Solar connectors (e.g. MC4)
  - B** - Solar wire

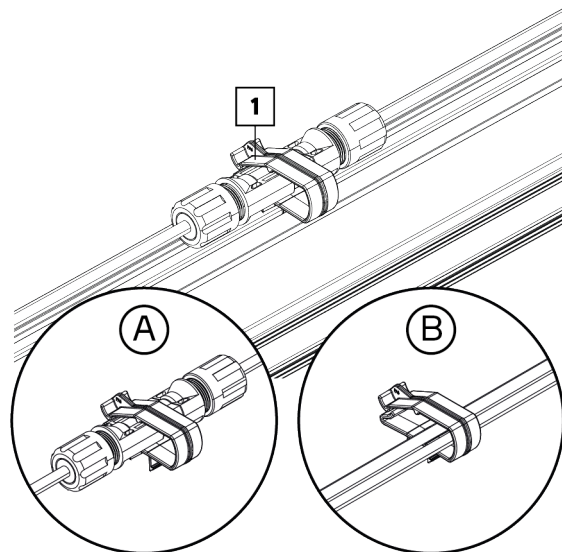

## MLPE MODULE MOUNTING (OPTIONAL)

### REQUIRED COMPONENTS

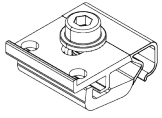

**OC-GA**  
Microinverter clamp universal

### ASSEMBLY



- ▶ Insert the clamp (1) into the MLPE device (2) as shown in the illustration.

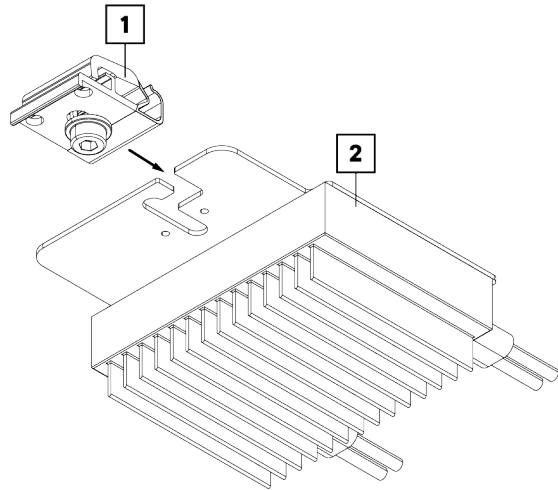

- ▶ The screw (1) must be positioned so that the stop bracket (2) of the clamp is in contact with the bracket.

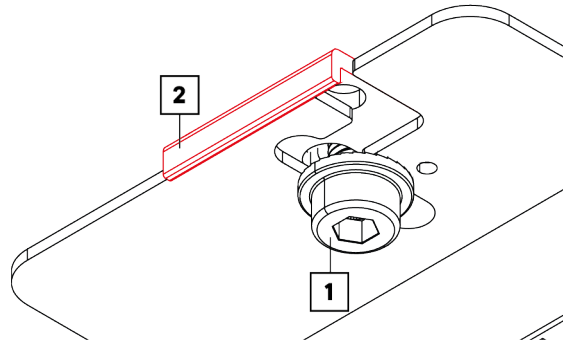

- ▶ Guide the MLPE (1) with the clamp to the underside of the module frame (2).
- ▶ Insert the clamp so that the module frame (2) is positioned between the upper and lower attachment of the clamp and rests on it.
- ▶ Then tighten the screw (3) with a torque of 10 Nm or 7.38 lb-ft.

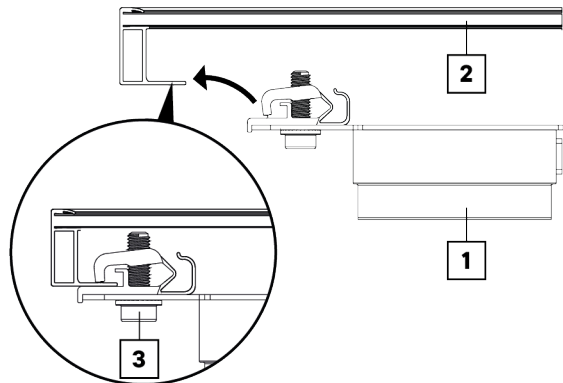



## MLPE FOR MOUNTING MOUNTING RAIL (OPTIONAL)

**i** The **SCR-MA** screw connection is intended for the mounting rails **X40**, **X50** and **X60**. In the following steps, the assembly is shown using an **X40** mounting rail. The procedure is identical for **X50** and **X60** mounting rails.

### NECESSARY COMPONENTS

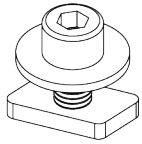

**SCR-MA**  
Bolting set module accessories



**X40-XXXX**  
Mounting rail X40 1980 mm 3300 mm 3550 mm 4400 mm 4750 mm 5500 mm 5850 mm

### ASSEMBLY (EXAMPLE MOUNTING RAIL X40)



- Insert the screw connection (1) into the MLPE device (2) as shown in the illustration.
- Ensure that the plate (3) is pointing downwards.

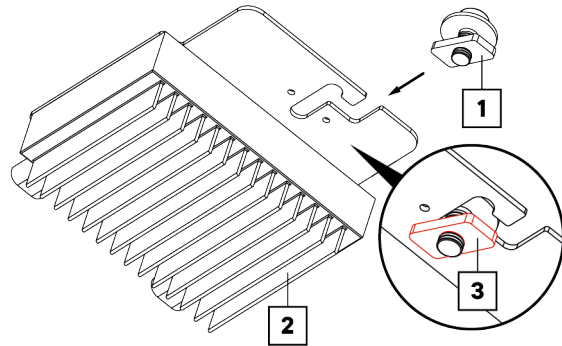

- Guide the MLPE (1) with the screw connection to the top of the mounting rail (2).
- Insert the plate (3) as shown in the illustration.

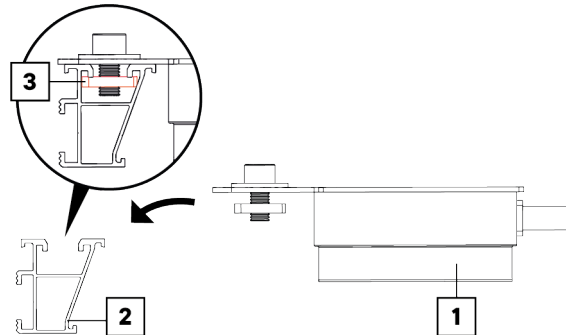

- Then tighten the Allen screw (1) with a torque of 15 Nm or 11 lb-ft.
- ☑ The MLPE is now mounted.

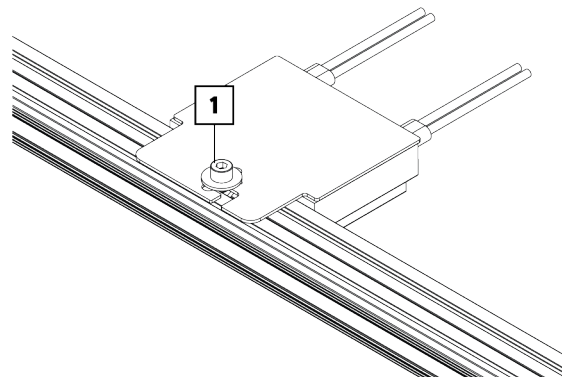

## POTENTIAL EQUALIZATION

**i** For potential equalization, **AEROCOMPACT Europe GmbH** provides the wire clamp as an accessory. These are each mounted on the mounting rail, depending on the mounting situation, the module rows are connected to each other by the module clamps.

### NECESSARY COMPONENTS

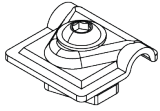

**WCL8-10**  
Wire clamp 8 - 10 mm



**X60-XXXX**  
Mounting rail X60 1980 mm 3550 mm 4750 mm 5850 mm

### MOUNTING WIRE CLAMP (EXAMPLE MOUNTING RAIL X60)



- Insert the wire clamp (1) into the mounting rail (3).
- Ensure that the threaded plate (2) is positioned as shown in the illustration.
- With the wire inserted, tighten the screw of the wire clamp (1) to a torque of 10 Nm or 7.38 lb-ft.

**i** In the following steps, the installation of the clamp is shown using an **X60** mounting rail. The procedure is identical for **X50** and **X40** mounting rails.

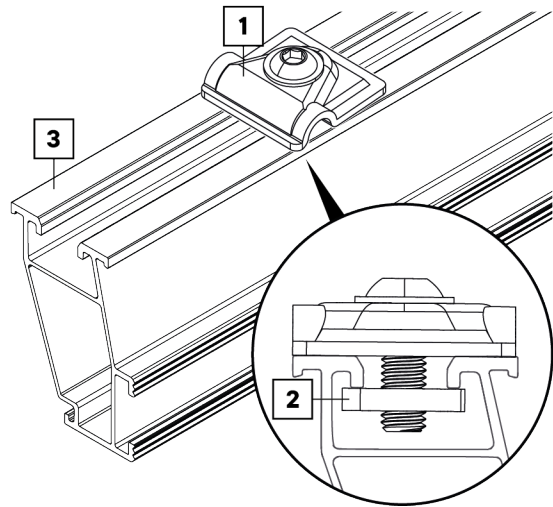

### MINIMUM CROSS-SECTIONS FOR EQUIPOTENTIAL BONDING

**i Caution!**

The specialist planner, contractor or installer is responsible for specifying the minimum cross-sections for equipotential bonding in accordance with the applicable legal requirements and standards. AEROCOMPACT Europe GmbH assumes no liability for this.



## WIRING DIAGRAM FOR EQUIPOTENTIAL BONDING

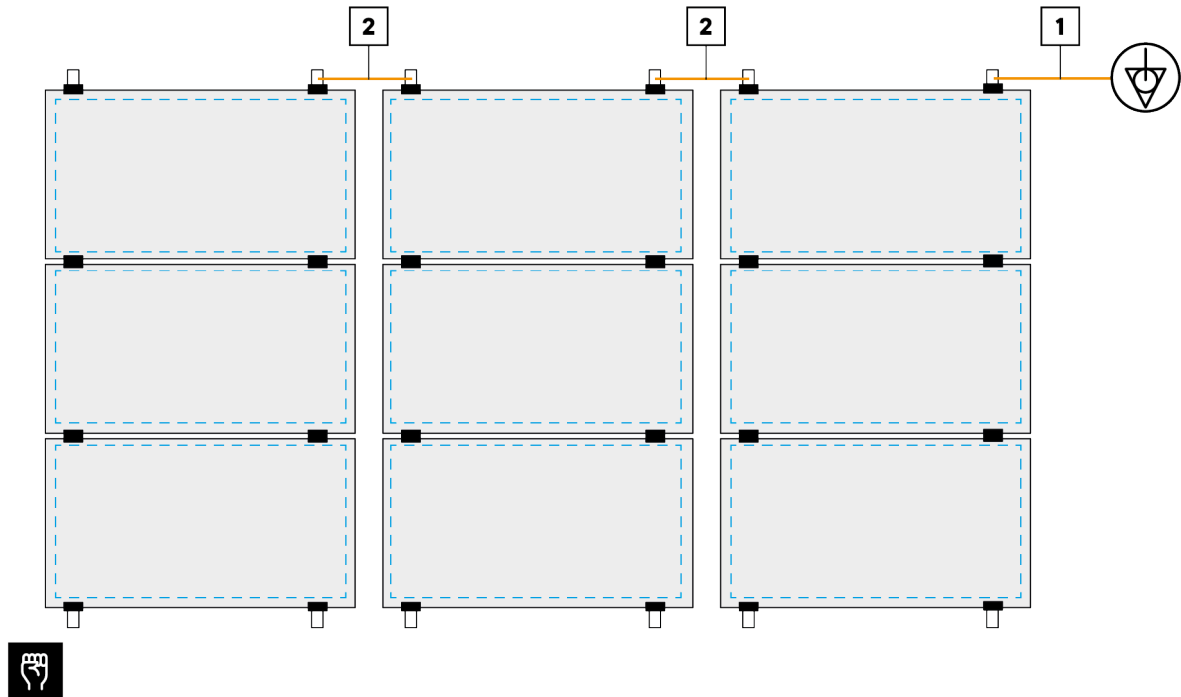

- Attach the on-site potential equalization (1) to a point on the system.
- Create a connection (2) for the module columns.

# MAINTENANCE, DISASSEMBLY AND DISPOSAL

## MAINTENANCE

To prevent personal injury and damage to property, the system must be checked regularly by qualified personnel and annual maintenance is required.

- Check all system components for damage. In the event of damage, replace the affected component immediately.
- Check all screw connections. Tighten loose screw connections, observing the tightening torque specified in the installation instructions.
- Checking all components for damage caused by the weather, animals, dirt, deposits, build-up, vegetation, roof penetrations, seals, stability and corrosion. In the event of damage, clean, repair or replace the affected component.

---

## DISASSEMBLY

### DISMANTLING THE CLAMPS (EXAMPLE)



**i** To disassemble the system, carry out the assembly steps in reverse order.

- ☒ Unscrew the screw (1) on the clamp.
- ☒ When reusing the clamp, ensure that the O-ring (2) is not lost.
- i** If the components are reused, it must be noted that these are wearing parts. Therefore, the AEROCOMPACT Europe GmbH cannot assume any responsibility for checking the degree of wear. For this reason, any liability or warranty of AEROCOMPACT Europe GmbH in case of reuse is excluded and reuse is at the installer's own responsibility.

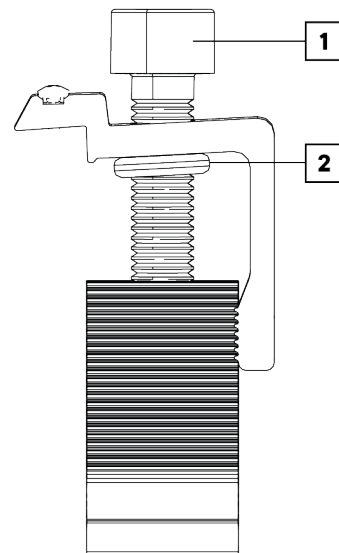

## DISPOSAL

Unless a take-back or disposal agreement has been made, disassembled components should be recycled:

- Give metals and plastic elements for recycling.
- Dispose of remaining components sorted according to material composition.

**i** Incorrect disposal may result in hazards to the environment. In case of doubt, obtain information on environmentally sound disposal from the local municipal authority or from specialized disposal companies.

# APPENDIX

## DECLARATION OF PERFORMANCE XW



Manufacturer: **AEROCOMPACT Europe GmbH**  
Designation: **Hanger bolt system CompactPITCH XW for corrugated fiber cement**  
Identification code: **XW**  
Applied standard: **EN 1090**  
Certification body: **2397**



[For the declaration of performance](#)

## REVISION HISTORY

Version	Chapter	Modification
v3.3	"MLPE module mounting (optional)" on page 24	New chapter added
	"Cable management" on page 20	New chapter added

---

**Europe / APAC**

AEROCOMPACT® Europe GmbH  
Gewerbestraße 14  
6822 Satteins  
Austria  
phone: +43 5524 22 566  
e-mail: [office@aerocompact.com](mailto:office@aerocompact.com)

**USA / Canada**

AEROCOMPACT® Inc.  
901A Matthews Mint Hill Road  
Matthews, NC 28105  
USA  
phone: +1 800 578 0474  
e-mail: [office.us@aerocompact.com](mailto:office.us@aerocompact.com)

**India**

AEROCOMPACT® India Private Ltd.  
Hub and Oak  
C-360, Defence Colony  
New Delhi, 110024  
phone: +91 888 26 32 902  
e-mail: [office.in@aerocompact.com](mailto:office.in@aerocompact.com)

---

